



BOWFLEX

XTREME 2 SE



The Bowflex Xtreme® 2 SE Home Gym Assembly Manual

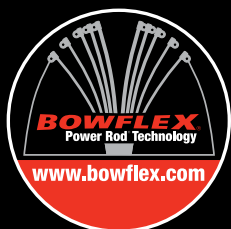

Congratulations on your commitment to fitness and your purchase of the Bowflex Xtreme® 2 SE home gym. Before assembling your Bowflex Xtreme® 2 SE home gym please read the Assembly Manual and follow the Important Safety Precautions. For information on how to use your Bowflex Xtreme® 2 SE home gym, refer to the Bowflex Xtreme® 2 SE Owner's Manual.

Nautilus, Inc.
16400 S.E. Nautilus Drive
Vancouver, Washington, USA 98683

1-800-NAUTILUS (1-800-628-8458)
Fax (800) 898-9410
Nautilus.com
Bowflex.com

Table of Contents

Important Safety Precautions	1
Getting To Know Your Machine	2
Parts Reference Guide	3
Hardware Guide	5
Assembly Guide	6
Cable & Pulley Routing	16
Important Contact Numbers	31

Specifications / Approvals

Product Specifications:

Product Weight	157 lbs. (71 kg)
Product Dimensions	53" (135 cm) long x 49" (124 cm) wide x 82" (208 cm) high
Workout Area	96" (244 cm) long x 78" (198 cm) wide
Number of Exercises	Over 70
Power Rod® Resistance	210 lbs. (95 kg)
Power Rod® Upgradability	310 lbs. (141 kg.) 410 lbs. (186 kg.)
User Weight Limit	300 lbs. (136 kg)

Regulatory Approvals:



Meets:

EN957-1 Class H

EN957-2 Class H

Meets:

ASTM F2276-05

ASTM F2216-05

Important Safety Precautions

IMPORTANT SAFETY INSTRUCTIONS

The following definition applies to the word “**WARNING**” found throughout this manual:



Used to call attention to **POTENTIAL** hazards that could result in personal injury or loss of life.



**READ ALL INSTRUCTIONS
BEFORE USING THE MACHINE.**



Getting to Know Your Machine

Before You Assemble

Please take the time to read all assembly instructions before attempting to assemble your Bowflex Xtreme® 2 SE home gym. Select where you are going to locate your machine carefully. The best place for your Bowflex Xtreme® 2 SE home gym is on a hard, level surface.

Select a workout area that provides a minimum clearance behind the rod box of 0.5 ft (15 cm) and a total width of 6.5 ft (2.0 m). Allow a minimum of 3.0 ft (0.9 m) free space in front of the machine.

Every effort has been made to provide you with a clear and accurate assembly manual. Should you find any inconsistencies, have questions about your Bowflex Xtreme® 2 SE or have suggestions for improving our manuals, please call 800-628-8458 for assistance

Basic Assembly Principles

Here are a few basic tips that will make your assembly of the Bowflex Xtreme® 2 SE home gym quick and easy. By using these principles, you can simplify each process and save yourself extra time and effort.

1. To make the assembly process go faster, gather the pieces you need for each step and thoroughly read the assembly instructions for that step prior to starting assembly for the step.
2. When tightening a locknut on a bolt, use a combination wrench to grip the locknut and ensure that it is fastened securely.
3. When attaching two pieces, gently lift and look through the bolt holes to help guide the bolt through the holes.
4. As a general rule, and for all bolts and nuts on your Bowflex Xtreme® 2 SE home gym, turn bolts or nuts toward the right (clockwise) to tighten and left (counterclockwise) to loosen. Or you can remember the mnemonic: "Righty tighty, lefty loosey."

IMPORTANT: LEAVE ALL CABLES COILED AND WRAPPED UNTIL YOUR BOWFLEX XTREME® 2 SE HOME GYM IS FULLY ASSEMBLED.

Parts Reference Guide

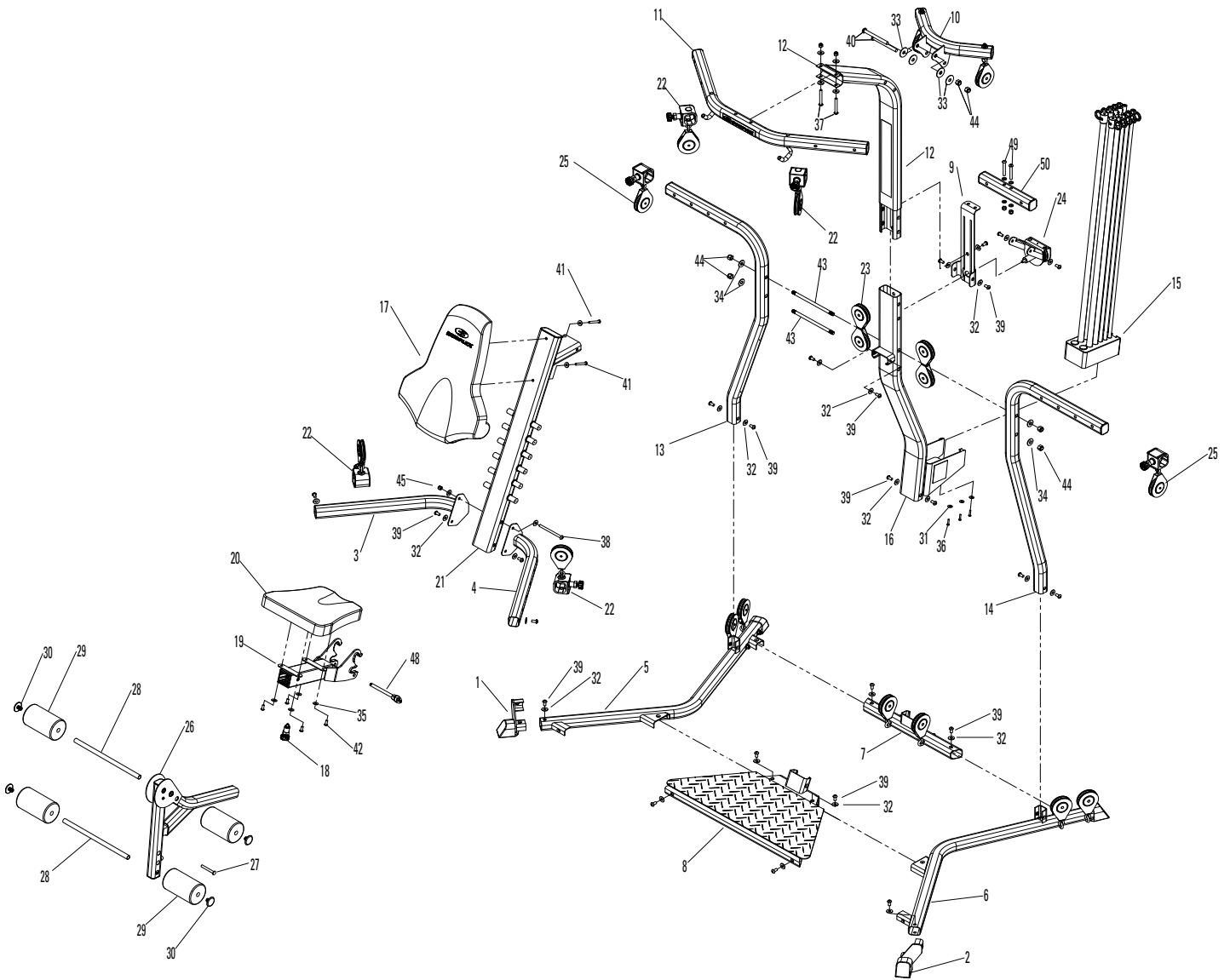

NOTE:
CABLES ARE NOT SHOWN FOR CLARITY

Parts Reference Guide

ITEM	QTY	DESCRIPTION
1	1	CONNECTOR, SQUAT FRAME LEFT
2	1	CONNECTOR, SQUAT FRAME RIGHT
3	1	SQUAT FRAME LEFT
4	1	SQUAT FRAME RIGHT
5	1	BASE FRAME, LEFT
6	1	BASE FRAME, RIGHT
7	1	BASE REAR CROSSMEMBER
8	1	SQUAT PLATFORM
9	1	AB CRUNCH BRACKET
10	1	REAR LAT CROSSMEMBER
11	1	LAT CROSS BAR ASSEMBLY
12	1	UPPER LAT TOWER TUBE
13	1	PULLEY ARM ASSEMBLY, RIGHT
14	1	PULLEY ARM ASSEMBLY, LEFT
15	1	BFX ROD PACK 210#
16	1	LOWER LAT TOWER
17	1	SEAT BACK PAD
18	1	LOCK KNOB
19	1	SEAT BACKBONE ASSEMBLY
20	1	SEAT BOTTOM
21	1	SEAT SUPPORT RAIL
22	4	PULLEY SLIDER, 4" w/o DECAL
23	2	PULLEY, PAIR FLOATING
24	1	LAT DBL PULLEY / HOUSING
25	2	PULLEY SLIDER, 4" w/ DECAL
26	1	LEG EXTENSION BACKBONE
27	1	LEG EXTENSION PIN
28	2	TUBE, FOAM ROLLER
29	4	PAD, FOAM ROLLER
30	4	END CAP 3/4"

ITEM	QTY	DESCRIPTION
31	3	FLAT WASHER 0250 REGULAR BLKZ
32	35	FLAT WASHER 0375 REGULAR BLKZ
33	4	FLAT WASHER 0500 WIDE BLKZ
34	4	FLAT WASHER 0500 REGULAR BLKZ
35	6	FLAT WASHER 0313 REGULAR BLKZ
36	3	PHILLIPS SCREW #10-24x1
37	2	BUTTON HEAD SCREW 0.375-16x3
38	1	BUTTON HEAD SCREW 0.375-16x5
39	25	BUTTON HEAD SCREW 0.375-16x0.75
40	2	BUTTON HEAD SCREW 0.500-13x5.25
41	2	BUTTON HEAD SCREW 0.3125-18x2.5
42	4	BUTTON HEAD SCREW 0.3125-18x0.75
43	2	THREADED STUD 0.500-13x9.5
44	6	NYLOCK NUT 0.500-13
45	5	NYLOCK NUT 0.375-16
46	1	ROD CABLES ASSEMBLY, PR
47	1	SQUAT CABLES ASSEMBLY, PR
48	1	SEAT LOCKING PIN
49	2	BUTTON HEAD SCREW 0.375-16x2.75
50	1	AB CRUNCH CROSSBAR

Hardware Guide

Tools you will need:

You will need the tools listed below to complete the assembly of your Bowflex Xtreme® 2 SE home gym. If you don't have these tools, you can find them at any hardware or department store.

- 7/16" Combination Wrench
- 9/16" Combination Wrench
- Adjustable Wrench
- Socket Wrench Set
- Phillips Screw Driver
- Flat Blade Screw Driver
- Rubber Mallet
- Utility Knife
- Scissors
- Hex wrenches (included)

Hardware card layout (NOTE: Drawings not to scale.)

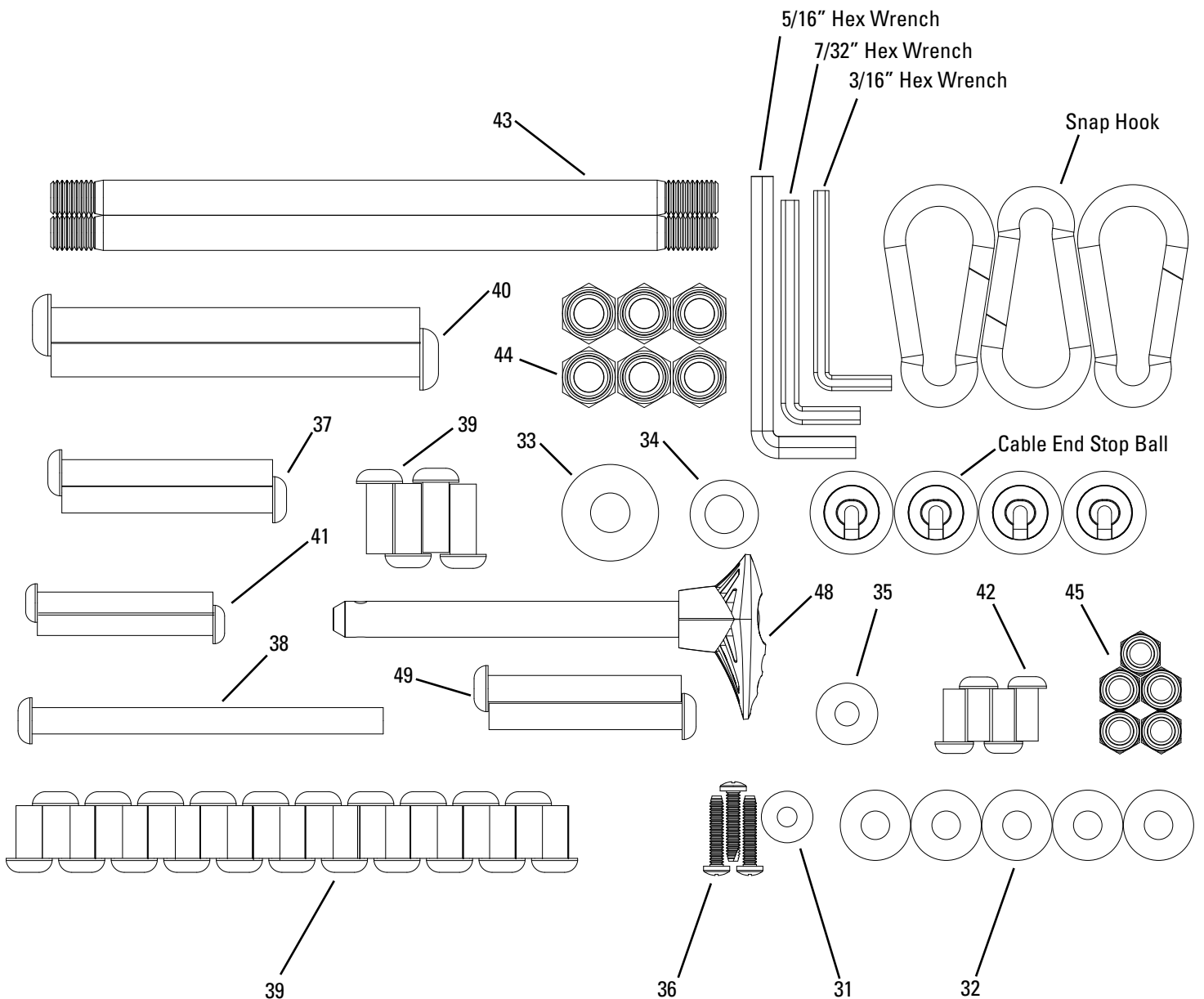

Assembly Guide

Step 1 Base Frame Assembly

Parts:

- Base Frame
- Left Frame Rail
- Right Frame Rail
- Rear Cross Member

Hardware:

- 6 Button Head Screws (3/8" X 3/4")
- 6 Flat Washers (3/8")

Tool: 7/32" Hex Wrench

1-1 Lay all parts on floor as shown.

1-2 Insert Frame Rail connectors into the Base Frame and Rear Cross Member. Secure with screws and washers as shown.

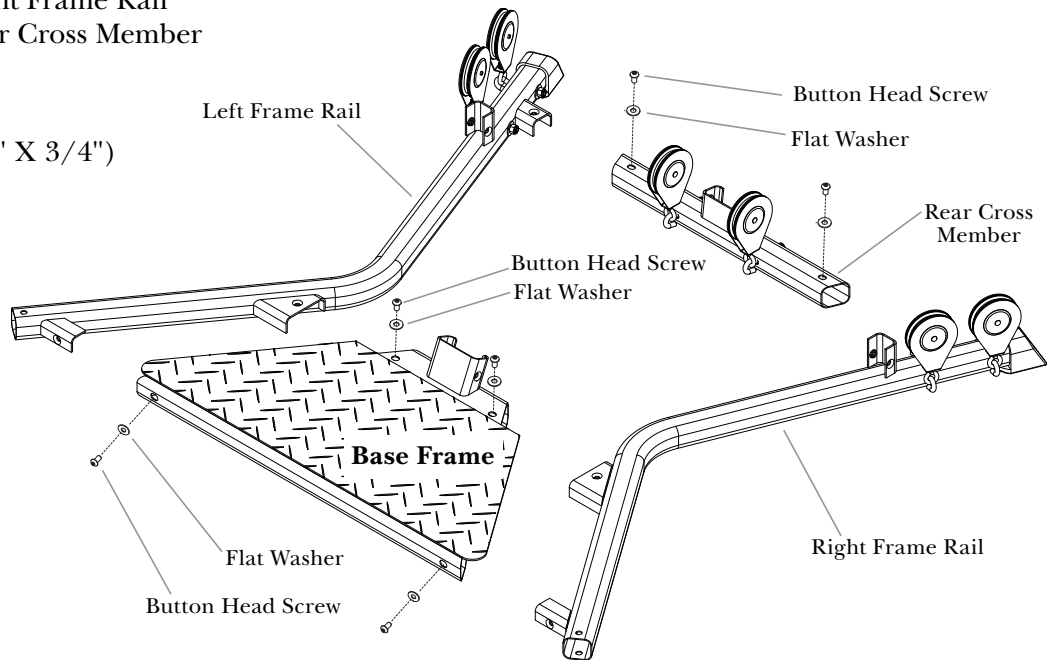

Finger tighten screws at this time.

Step 2 Lower Lat Tower Assembly

Parts:

- Lower Lat Tower Frame
- Rod Box with Power Rod® Pack

Hardware:

- 3 Phillips Screws (#10 X 1")
- 3 Flat Washers (1/4")

Tool: Phillips Screw Driver

2-1 Lay parts on floor as shown. Firmly slide Rod Box into Lower Lat Tower Frame.

2-2 Fasten the Rod Box to the Lower Lat Tower Frame with screws and washers as shown. Tighten screws until snug.

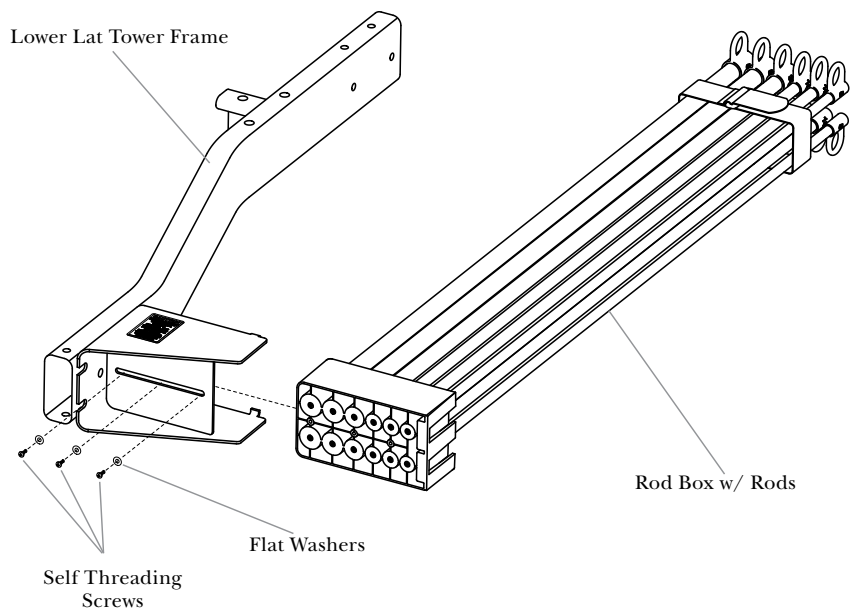

Assembly Guide

Step 3 Install Lower Lat Tower Assembly

Parts:

- Lower Lat Tower Assembly
- Base Frame Assembly

Hardware:

- 2 Button Head Screws (3/8" X 3/4")
- 2 Flat Washers (3/8")

Tool: 7/32" Hex Wrench

3-1 Align the Lower Lat Tower Assembly over the Base Frame. Push the bottom of the Lower Lat Tower onto the connector of the Rear Cross Member as shown.

3-2 Secure Lower Lat Tower Assembly using screws and washers as shown.

Finger tighten screws at this time.

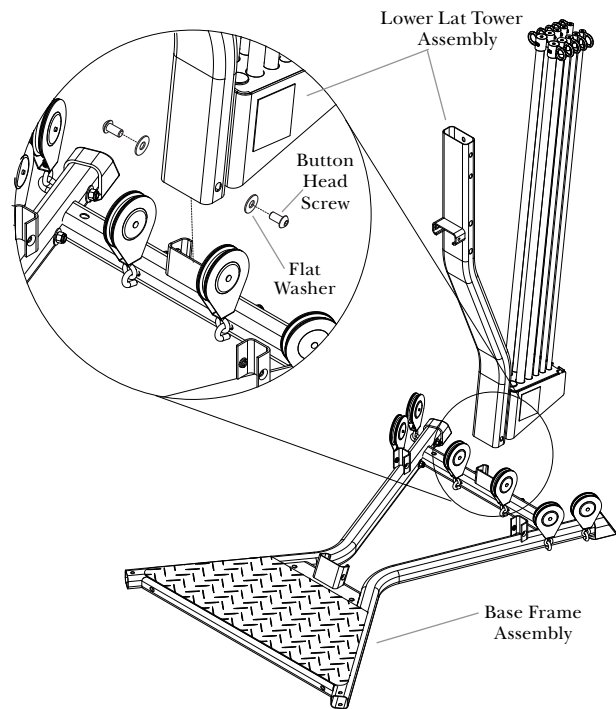

Step 4 Install Seat Support Rail

Parts:

- Seat Support Rail
- Base Frame Assembly

Hardware:

- 2 Button Head Screws (3/8" X 3/4")
- 2 Flat Washers (3/8")

Tool: 7/32" Hex Wrench

4-1 Slide the bottom of the Seat Support Rail onto the Base Frame connector as shown.

4-2 Slide the top of the Seat Support Rail onto the Lower Lat Tower Assembly connector as shown. Secure using screws and washers as shown.

Finger tighten screws at this time.

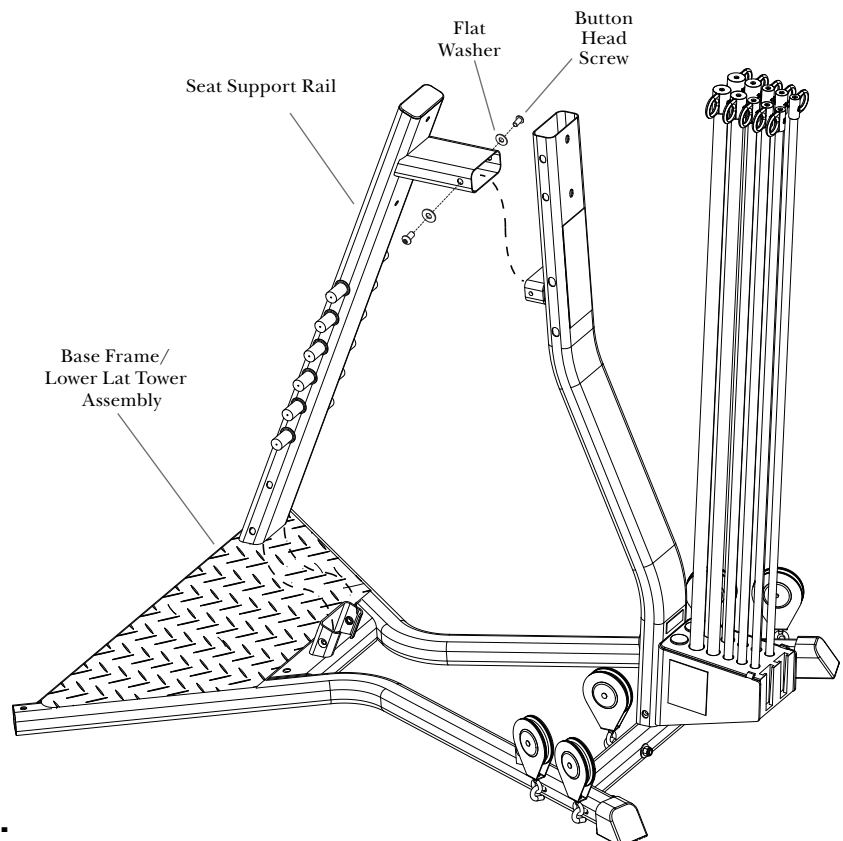

Assembly Guide

Step 5 Install Squat Pulley Frame

Parts:

- Left Squat Pulley Frame
- Right Squat Pulley Frame
- Main Assembly
- 2 Slider Pulleys w/o Decal
- Left Squat Frame Connector
- Right Squat Frame Connector

Hardware:

- 1 Button Head Screw (3/8" X 5")
- 1 Nylock Nut (3/8")
- 6 Button Head Screws (3/8" X 3/4")
- 8 Washers (3/8")

Tools: 7/32" Hex Wrench & Adjustable or Socket Wrench

5-1 Place one Squat Pulley Frame on each side of the Seat Support Rail as shown, and align the top screw holes. Secure using a 3/8" X 5" screw, washer and nut in the top hole as shown in **Detail 5a**.

5-2 Install screws and washers through the bottom holes of each Squat Pulley Frame into the Support Rail as shown in **Detail 5a**.

5-3 Slide one Slider Pulley onto the free end of the Left Squat Pulley Frame as shown in **Detail 5b**. Lock the pulley in position near the Support Rail.

5-4 Slide the Left Squat Frame Connector onto the end of the Left Frame Rail and the Left Squat Pulley Frame.

5-5 Install screws and washers to secure the Squat Frame Connector to the Squat Pulley Frame and the Frame Rail as shown in **Detail 5b**.

5-6 Repeat Steps 5-3 through 5-5 for the Right Squat Pulley Frame.

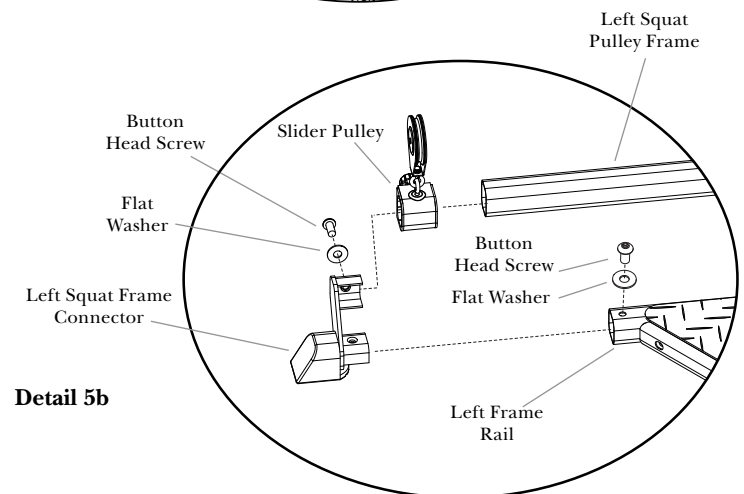
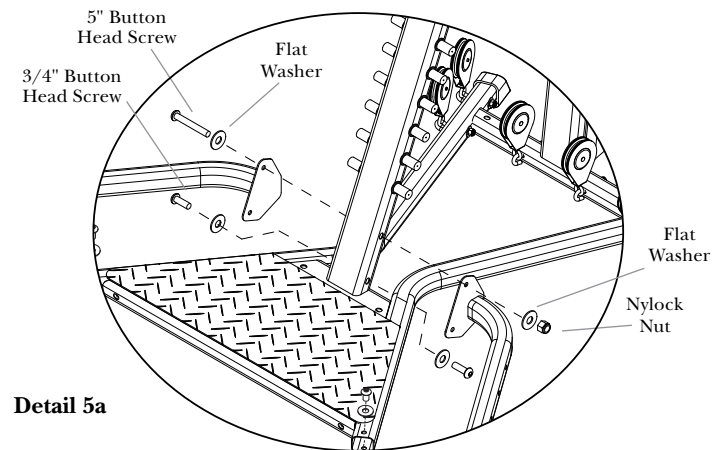
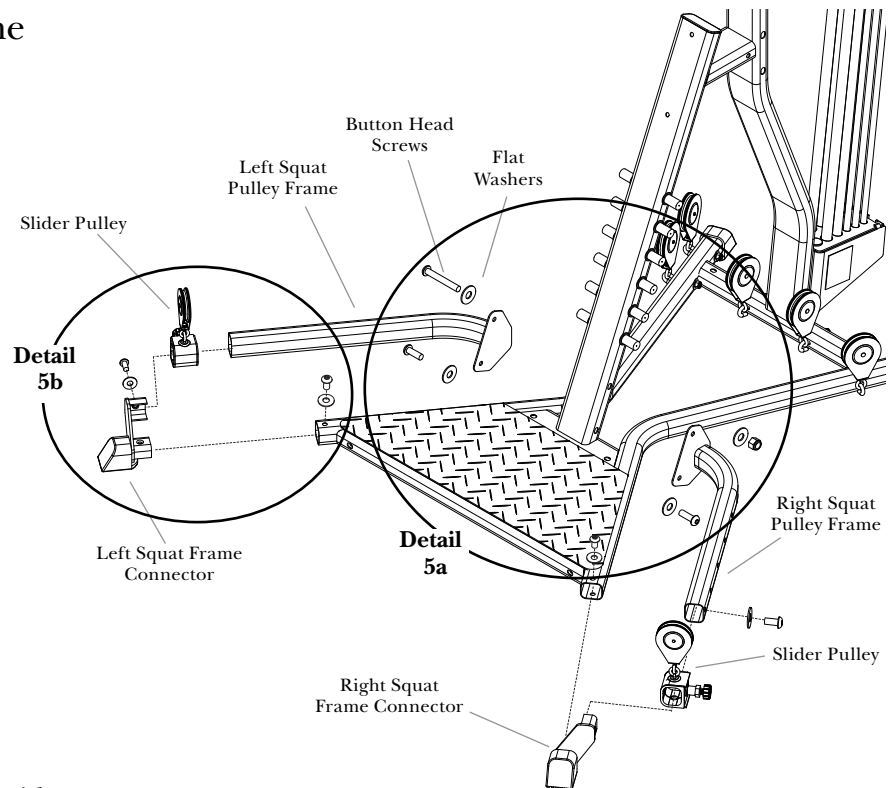

Assembly Guide

Step 6 Install Pulley Arms

Parts:

- Right Pulley Arm
- Left Pulley Arm
- Main Assembly

Hardware:

- 4 Washers (3/8")
- 4 Button Head Screws (3/8" X 3/4")
- 2 Threaded Studs (1/2" X 9 1/2")
- 4 Nylock Nuts (1/2")
- 4 Washers (1/2")

Tools: 7/32" Hex Wrench, Rubber Mallet

6-1 Slide Left and Right Pulley Arms onto the connectors on the base frame as shown.

6-2 Secure Pulley Arms to Base Frame using 3/8" screws and washers as shown.

Finger tighten screws at this time.

6-3 Align the two holes in the Pulley Arms with those in the Lower Lat Tower Assembly and secure using threaded studs, 1/2" washers and nuts as shown.

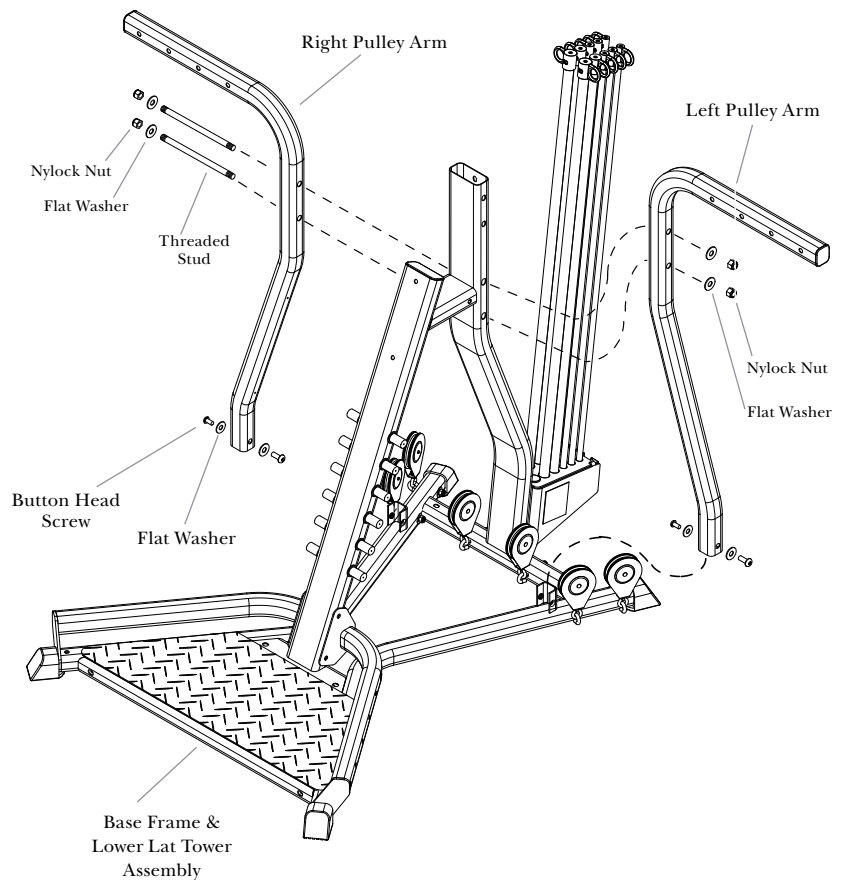

Step 7 Install Slider Pulleys

Parts:

- 2 Slider Pulleys w/ Decal
- Main Assembly

Tools: 3/16 Hex Wrench

7-1 Install a Slider Pulley onto each Pulley Arm as shown.

7-2 Choose any of the four holes to secure.

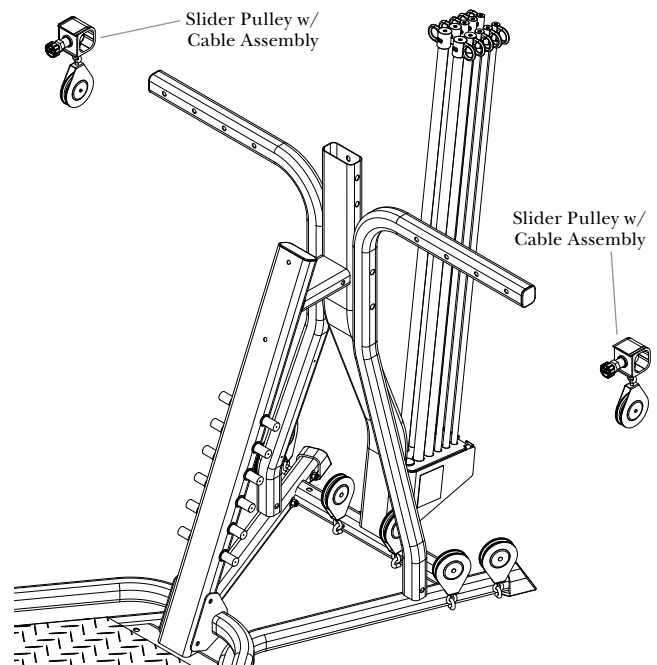

Assembly Guide

Step 8 Seat Assembly

Parts:

- Seat Backbone
- Seat Bottom

Hardware:

- 4 Button Head Screws (5/16" X 3/4")
- 4 Washers (5/16")

Tool: 3/16" Hex Wrench

- 8-1** Install the Seat Backbone to the underside of the Seat Pad using screws and washers as shown.

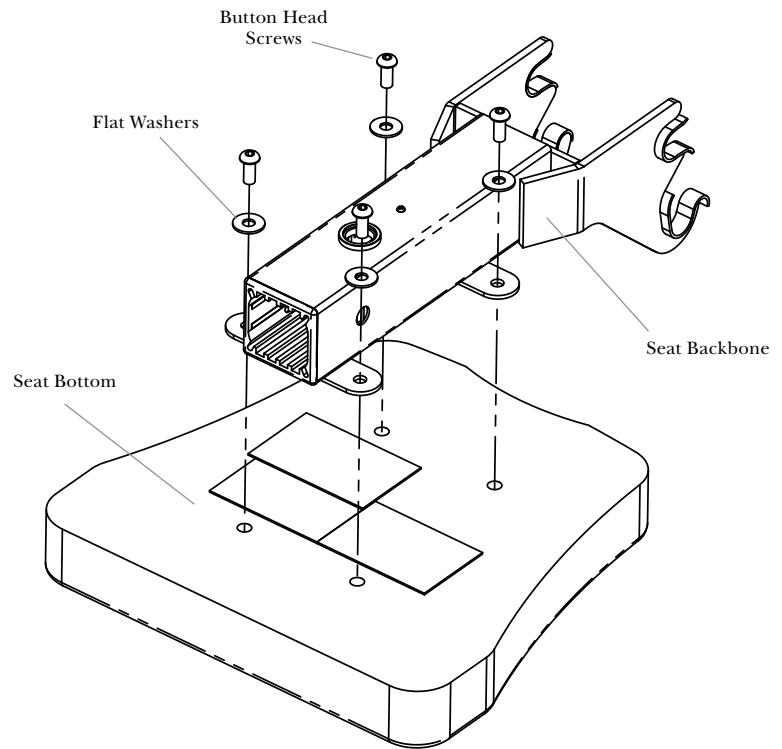

Step 9 Leg Extension Assembly

Parts:

- Leg Extension Backbone
- 2 Chrome Tubes
- 4 Foam Rollers
- 4 End Caps

Tool: Rubber Mallet

- 9-1** Insert Chrome Tubes through the upper hole and one of the lower holes in the Leg Extension. (Select hole for your comfort level.)

- 9-2** Slide Foam Rollers onto the Chrome Tubes and secure with end caps. A rubber mallet may be needed to secure the end caps.

NOTE: The Leg Extension may be adjusted during workout to best suit your height and personal preferences.

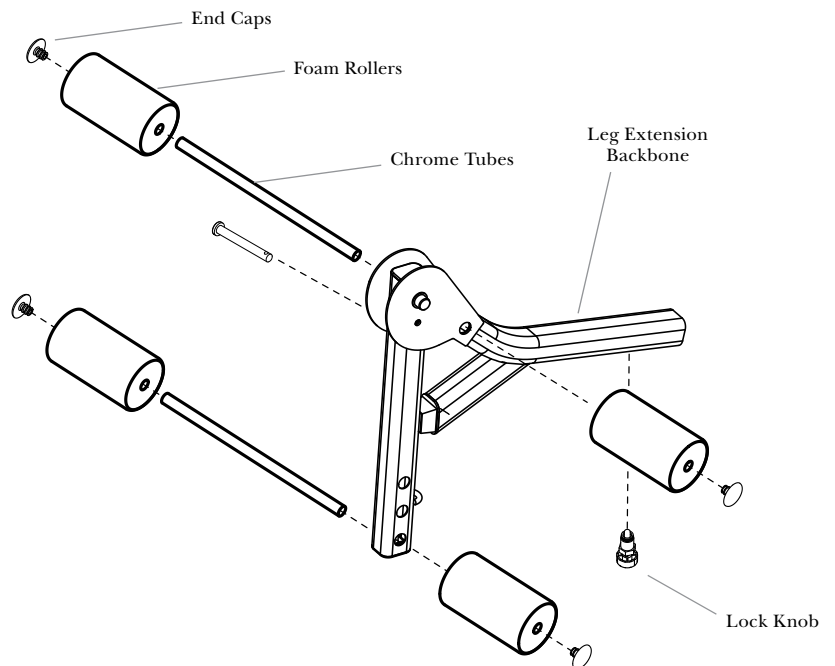

Assembly Guide

Step 10 Install Leg Extension Assembly

Parts:

- Leg Extension Assembly
- Lock Knob
- Seat Assembly

10-1 Insert Leg Extension Backbone into open end of Seat Backbone as shown.

10-2 Align one hole of the Leg Extension with the hole in the Seat Backbone to fit your height and secure with the Lock Knob as shown.

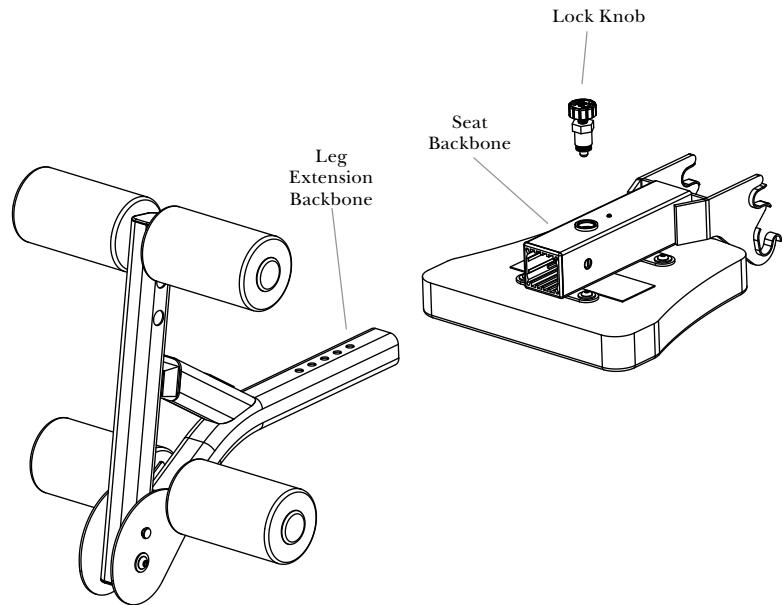

Step 11 Install Seat Back Pad

Note: The back of the Seat Back Pad has two pairs of holes. Select the appropriate set based on your height.

Parts:

- Seat Back Pad
- Main Assembly

Hardware:

- 2 Button Head Screws (5/16" X 2 1/2")
- 2 Washers (5/16")

Tool: 3/16" Hex Wrench

11-1 Position Seat Back Pad against the Seat Support Rail and align the screw holes for your height with those on the Seat Support Rail.

11-2 Secure Seat Back Pad to the Seat Support Rail using screws and washers as shown.

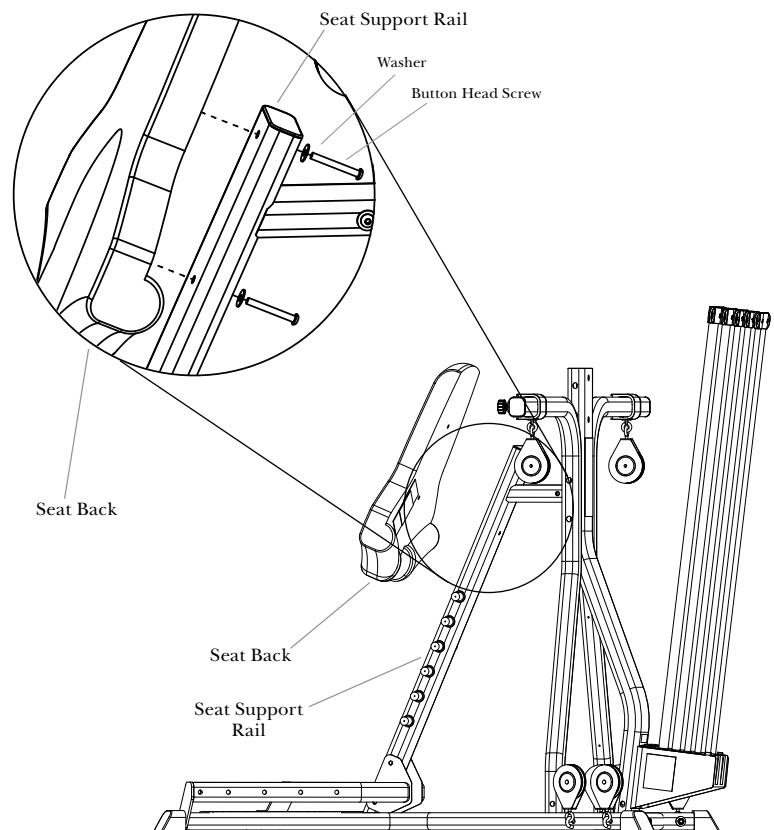

Assembly Guide

Step 12 Install Seat Assembly

Parts:

- Seat Assembly
- Seat Locking Pin
- Main Assembly

12-1 Align the top two hooks on the Seat Backbone with one of the pairs of pins on the Seat Support Rail, as shown in **Detail 12a**.

12-2 Tip seat front up and slide hooks onto pins. Rotate seat down and back to use.

12-3 Slide the Seat Locking Pin through the holes in the Seat Backbone hooks to secure the seat assembly on the Seat Support Rail as shown in **Figure 12b**.

Note: Reverse procedure to remove seat.

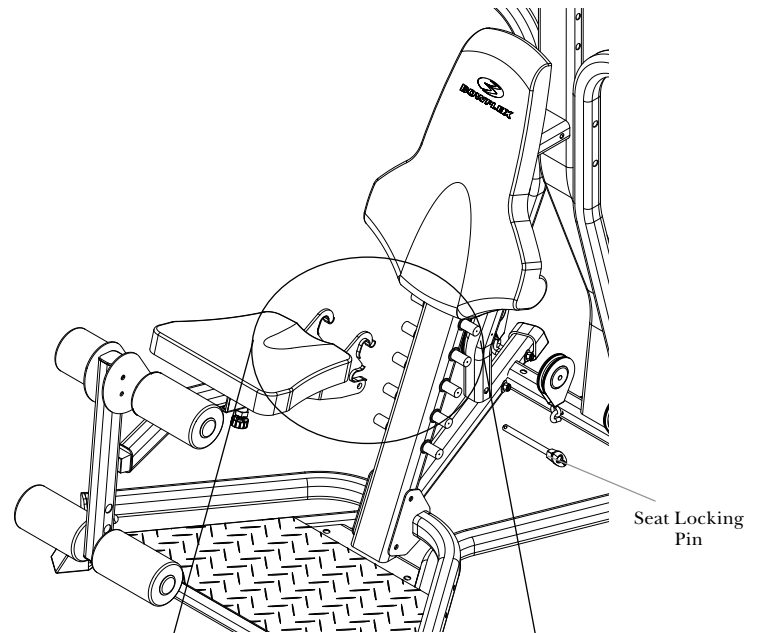

Detail 12a

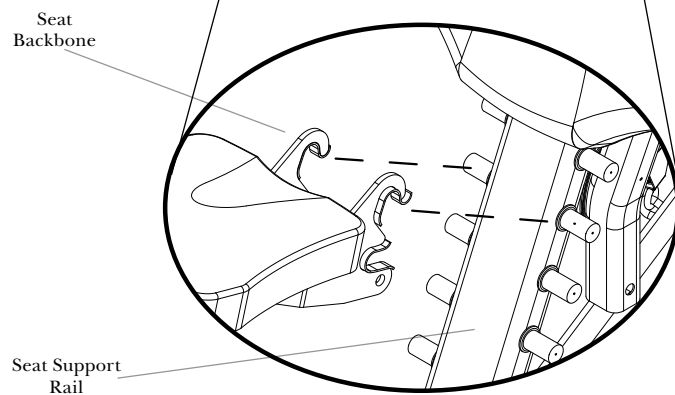

Detail 12b - Back View

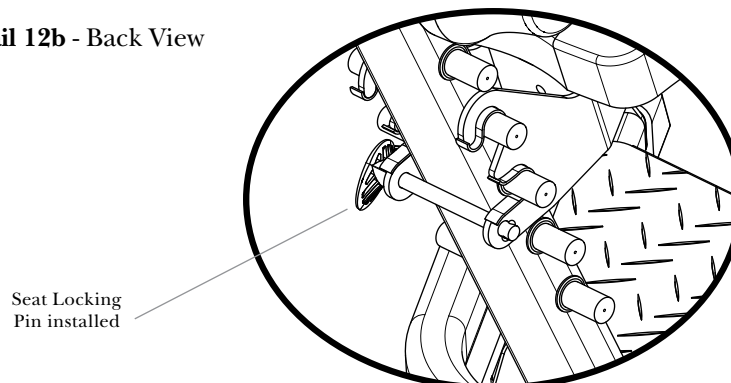

Assembly Guide

Step 13 Upper Lat Tower Assembly

Parts:

- Upper Lat Tower
- Lat Cross Bar
- Rear Lat Crossmember

Hardware:

- 2 Button Head Screws (3/8" X 3")
- 2 Washers (3/8")
- 2 Nylock Nuts (3/8")
- 2 Button Head Screws (1/2" X 5 1/4")
- 2 Wide Washers (1/2")
- 2 Nylock Nuts (1/2")

Tool: 7/32" Hex Wrench and Adjustable Wrench

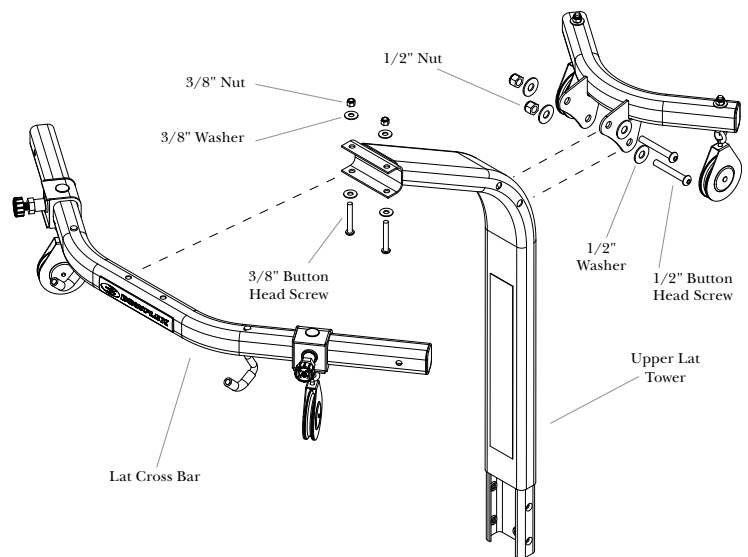

13-1 Align the two holes on the Lat Cross Bar with those on the Upper Lat Tower as shown.

13-2 Attach using 3/8" screws, washers and nuts as shown.

Note: Do not tighten hardware at this time.

13-3 Align the bracket on the Rear Lat Crossmember with the bolt on the Upper Lat Tower as shown.

13-4 Attach using 1/2" screws, washers and nuts as shown.

13-5 Tighten all hardware from this step.

Step 14 Ab Crunch Station Assembly

Parts:

- Ab Crunch Bracket
- Ab Cross Bar

Hardware (1:1):

- 2 Button Head Screws (3/8" X 2 3/4")
- 4 Washers (3/8")
- 2 Nylock Nuts 3/8-16

Tool: 7/32" Hex Wrench

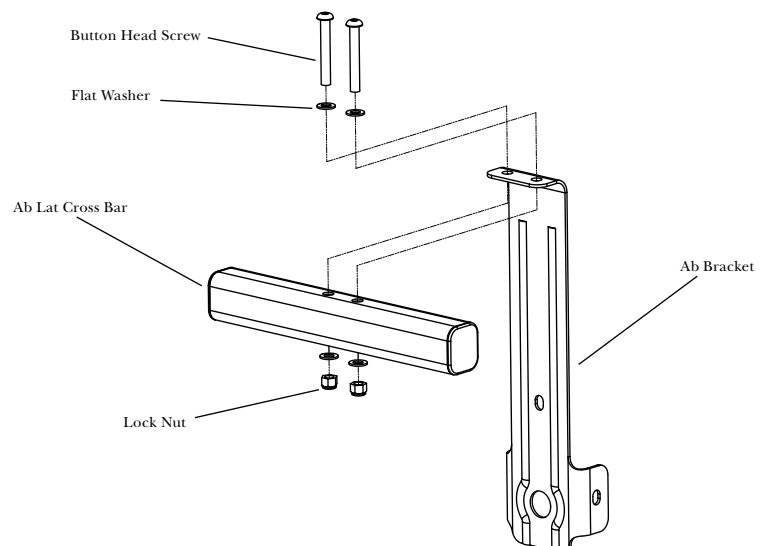

14-1 Attach the Ab Cross Bar to the Ab Crunch Bracket as shown. Tighten all hardware from this step.

Assembly Guide

Step 15 Install Upper Lat Tower Assembly, Ab Crunch Station and Lat Pulley

Parts:

- Upper Lat Tower Assembly
- Ab Crunch Station
- Lat Pulley Housing
- Main Assembly

Hardware:

- 5 Button Head Screws (3/8" X 3/4")
- 5 Flat Washers (3/8")

Tool: 7/32" Hex Wrench

15-1 Slide the Upper Lat Tower Assembly onto the Lower Lat Tower as shown.

15-2 Place the Ab Crunch Bracket against back of the Lat Tower Assembly. Align the bolt holes on the Ab Crunch Bracket's side flaps with the lower bolt holes on the sides of the Lat Tower.

15-3 To attach the Ab Crunch Station to the Lat Tower, install a 3/4" screw and washer through the upper bolt hole on the Ab Crunch Station into the back of the Lat Tower as shown in **Detail 15a**. Secure the Ab Crunch Station to the sides of the Lat Tower with 2 screws and washers as shown in **Detail 15a**.

15-4 Remove the plastic cap from the end of the the long bolt already installed in the back of the Lat Pulley/Housing. Finger tighten the bolt—it will be removed and reinstalled during Step 17 and 18.

15-5 Position the Lat Pulley Housing bracket against the Lat Tower, over the Ab Crunch Station. Align the bolt holes as shown in **Figure 15b**.

15-6 Place one washer over the end of each screw. Attach the Lat Pulley Housing to the Lat Tower by installing the screws loosely into the aligned holes as shown in **Figure 15b**.

Do not tighten hardware at this time.

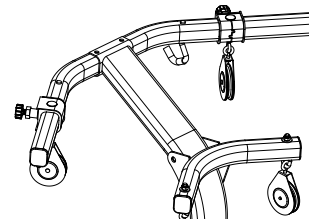

Figure 15a

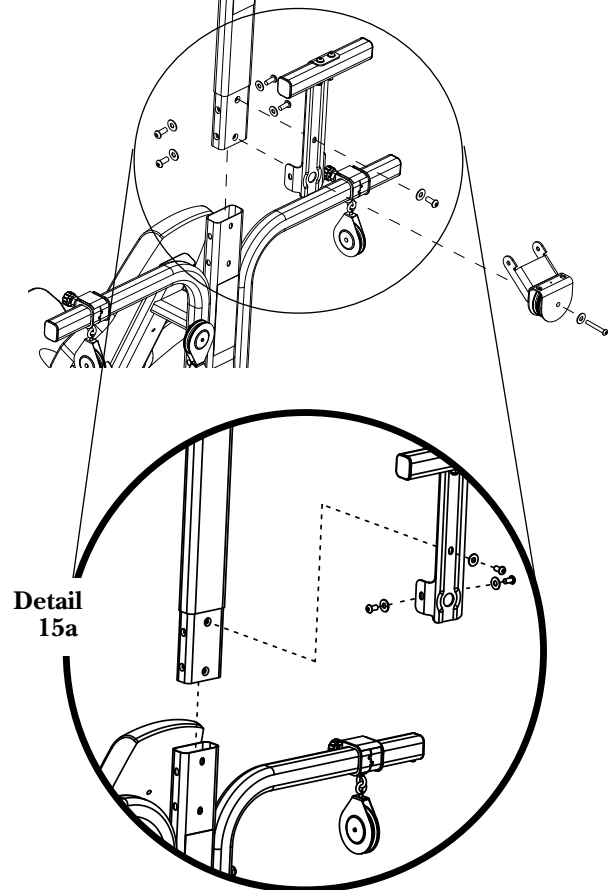
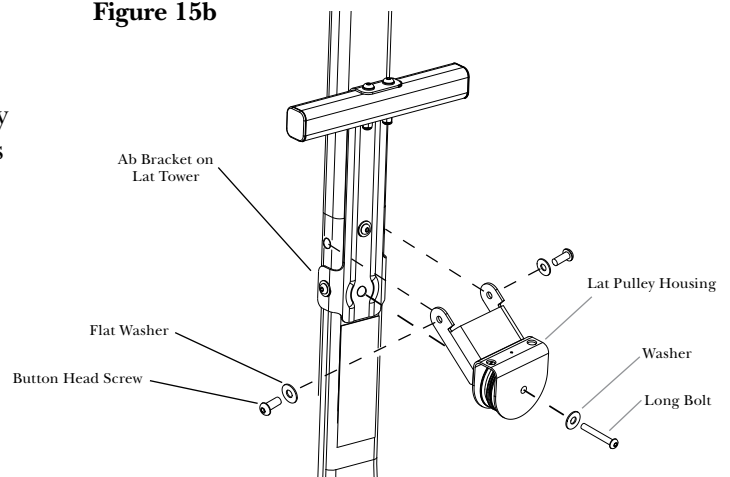

Figure 15b



Assembly Guide

Step 16 Cable and Pulley Routing – Overview

The figure below shows all Pulleys on the Bowflex Xtreme 2 SE home gym. Subsequent images show how to connect and route each of the Cables through the Pulleys. (The Ab Crunch Station is not shown for clarity.) Connecting the Cables is much easier with a second person assisting you.

All references to the right or left of the machine are from the viewpoint of standing in front of the machine facing the seat.

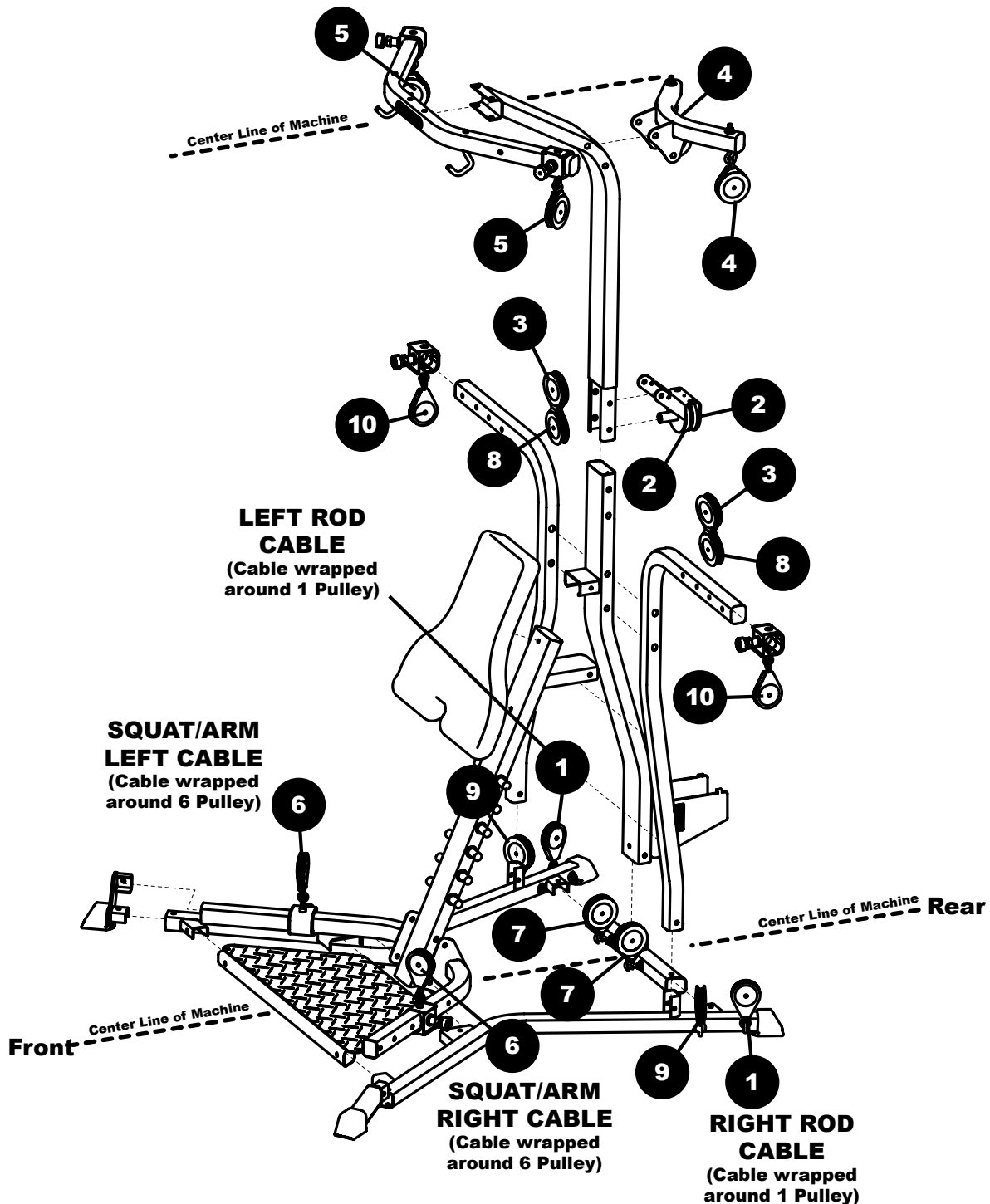

Assembly Guide

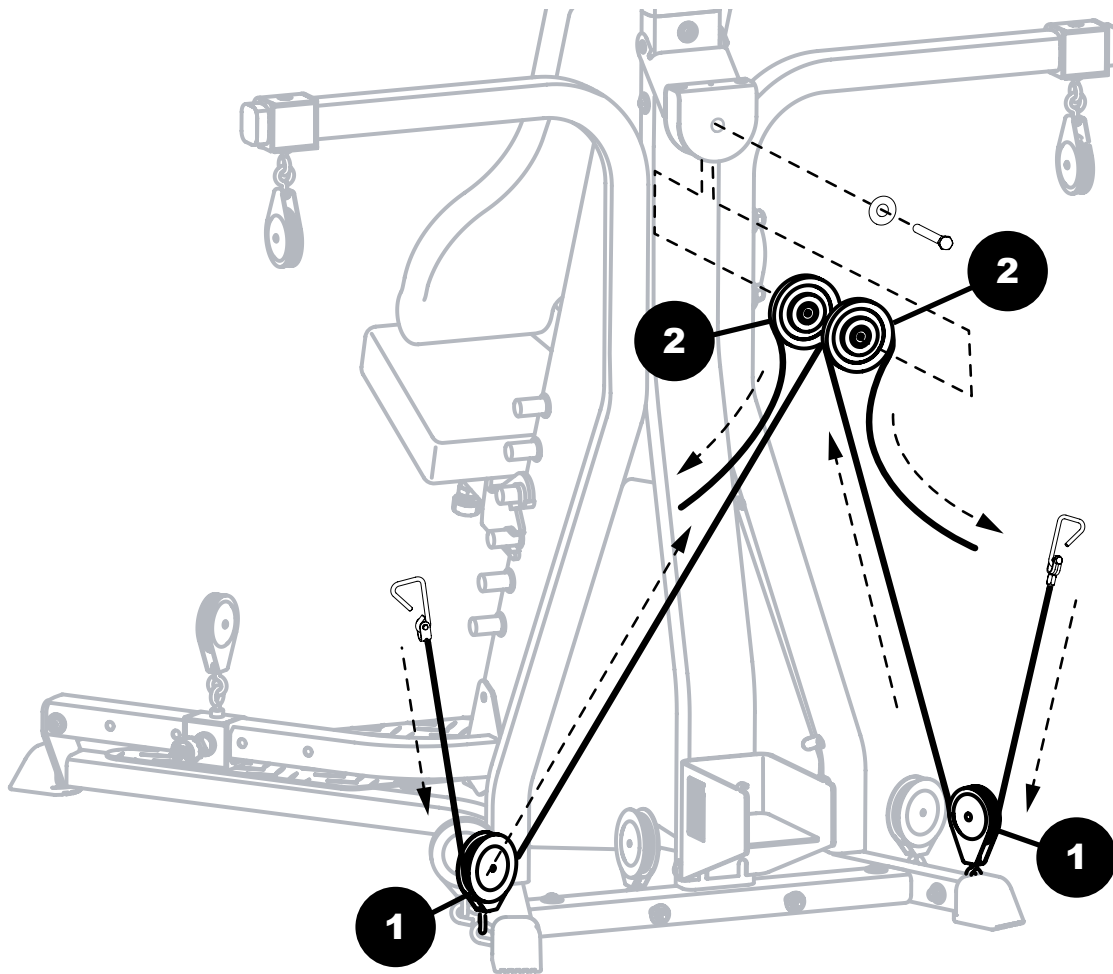

Step 17 Cable and Pulley Routing – Prepare Cables to be installed to the Lat Pulley Housing

Locate the following items on the Lat Pulley Housing assembly:

- (2) Pulleys – already installed, labeled as item 2 in figure
- 3/8" X 4 1/2" Hex Head Bolt – installed
- 3/8" Washer – already installed

Note: Connecting the Cables is much easier with a second person assisting you.

17-1 Remove the 4 1/2" Bolt and Washer from the back of the Lat Pulley Housing, and set safely aside for Step 18.

17-2 The 2 Pulleys will slide down and out of the housing without the hex bolt holding them in place. Unwrap the Right Pulley Cable on the Right Frame Rail. Thread the cable beneath and then over one Lat Pulley (2), following the arrows shown in **Figure 20** and holding the cable tightly where indicated.

17-3 Repeat for the Left Pulley Cable (on the Left Frame Rail), without loosening your grip on the Right Pulley Cable.

Assembly Guide

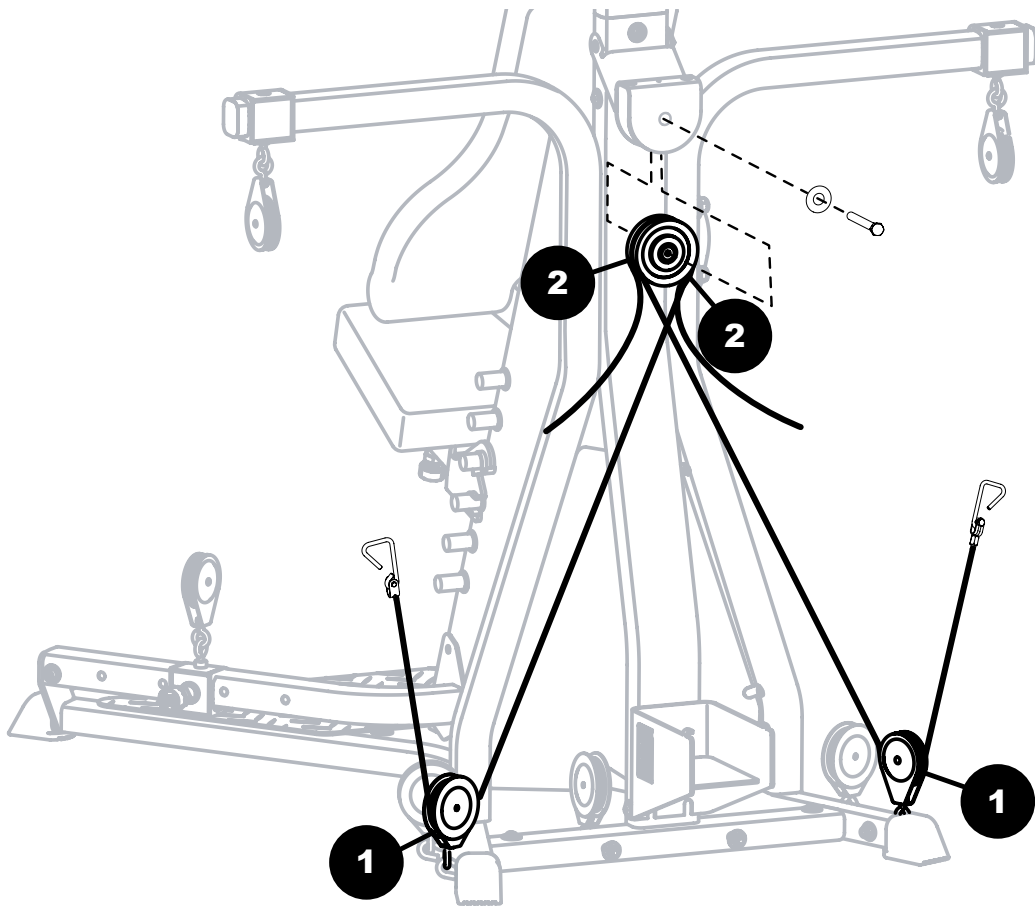

Step 18 Cable and Pulley Routing – Connect Pulleys and Cables to the Lat Pulley Housing

Locate the following items for the Lat Pulley Housing assembly:

- (2) Pulleys from step 17
- 3/8" X 4 1/2" Hex Head Bolt – uninstalled in Step 17
- 3/8" Washer – uninstalled in Step 17

Note: Connecting the Cables is much easier with a second person assisting you.

18-1 Holding both Cables from Step 17 in place, align the 2 Lat Pulleys as shown in **Figure 18**. Slide the Pulleys back into the Lat Pulley Housing, lining up the bolt holes in the Pulleys and Lat Pulley Housing.

18-2 Place the Washer over the 4 1/2" Bolt from Step 17. Slide the Bolt through the aligned holes in the Lat Pulley Housing and Lat Pulleys as shown in **Figure 18**.

Tighten all hardware.

Note: You will probably need to push the Power Rod® unit out of the way for this step. The Power Rod® unit is not pictured for the sake of clarity.

Assembly Guide

Step 19 Cable and Pulley Routing – Connect Rod Cables through the Right Floating and Lat Tower Pulleys

Locate the following items for the Lat Pulley Housing assembly:

- 3 & 8 Floating Pulleys (connected unit)
- (2) Cable End Stop Balls with Core (see Detail)

19-1 Locate the Right Rod Cable that you ran through the Lat Pulley Housing. Thread the Cable through the (3) Floating Pulley, as shown.

19-2 Continue to guide the Cable through the (4) Pulley on the Rear Lat Cross Bar, and then through the (5) Pulley on the Front Lat Cross Bar as shown.

19-3 Insert the Cable End through the Cable End Stop Ball, and attach the Cable Core to keep the Cable from slipping back through the Pulleys. See **Figure 19b**.

Note: The Cable End Stop Ball Core should fit over the Ferrule when installed correctly. Rotate the Core to align it with the groove in the Ball.

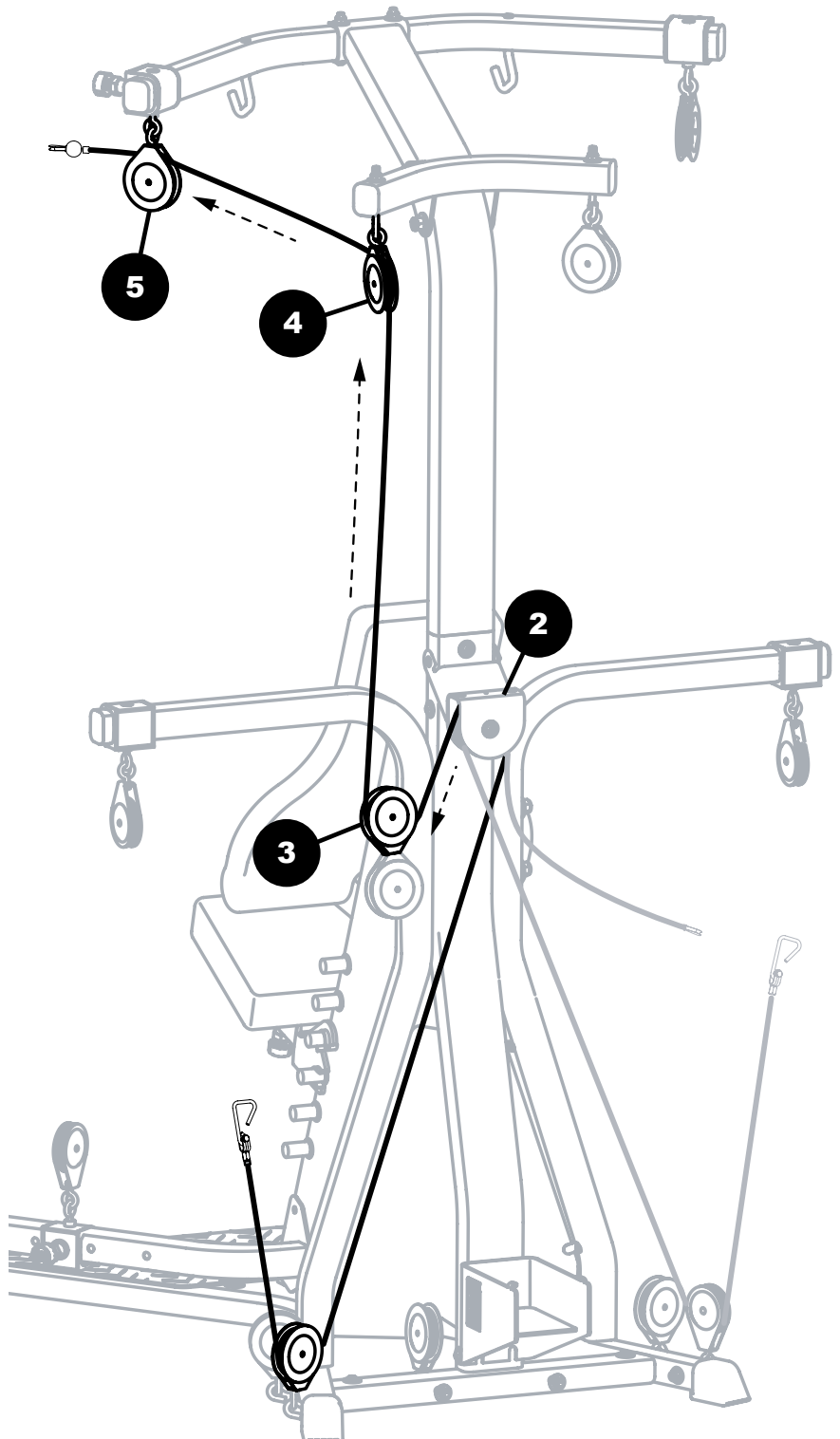

Assembly Guide

Step 19b Cable and Pulley Routing – Connect Cable End Stop Ball with Core

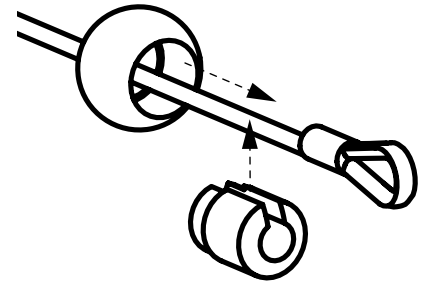

Figure 19b - Detail

Step 19c Cable and Pulley Routing – Connect Rod Cables through Left (3) Floating and Lat Tower Pulleys

19-4 Repeat with Left Rod Cable and (3) and (8) Floating Pulleys, as shown in **Figure 19c**.

Note: Once the Cable End Stop Balls are attached, hook each Rod Hook onto the Lat Pulley Housing as shown in **Figure 19d**.

Figure 19c

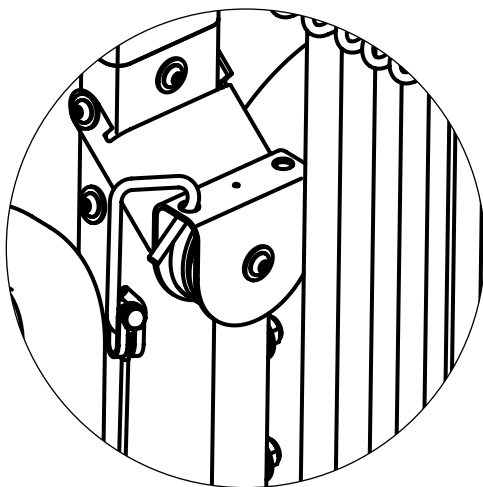
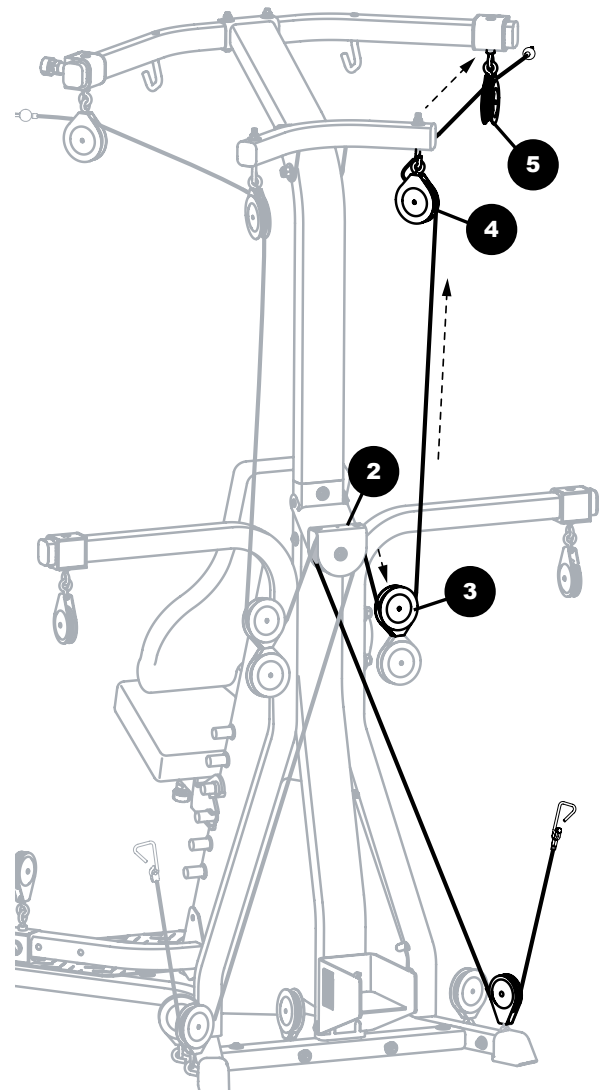
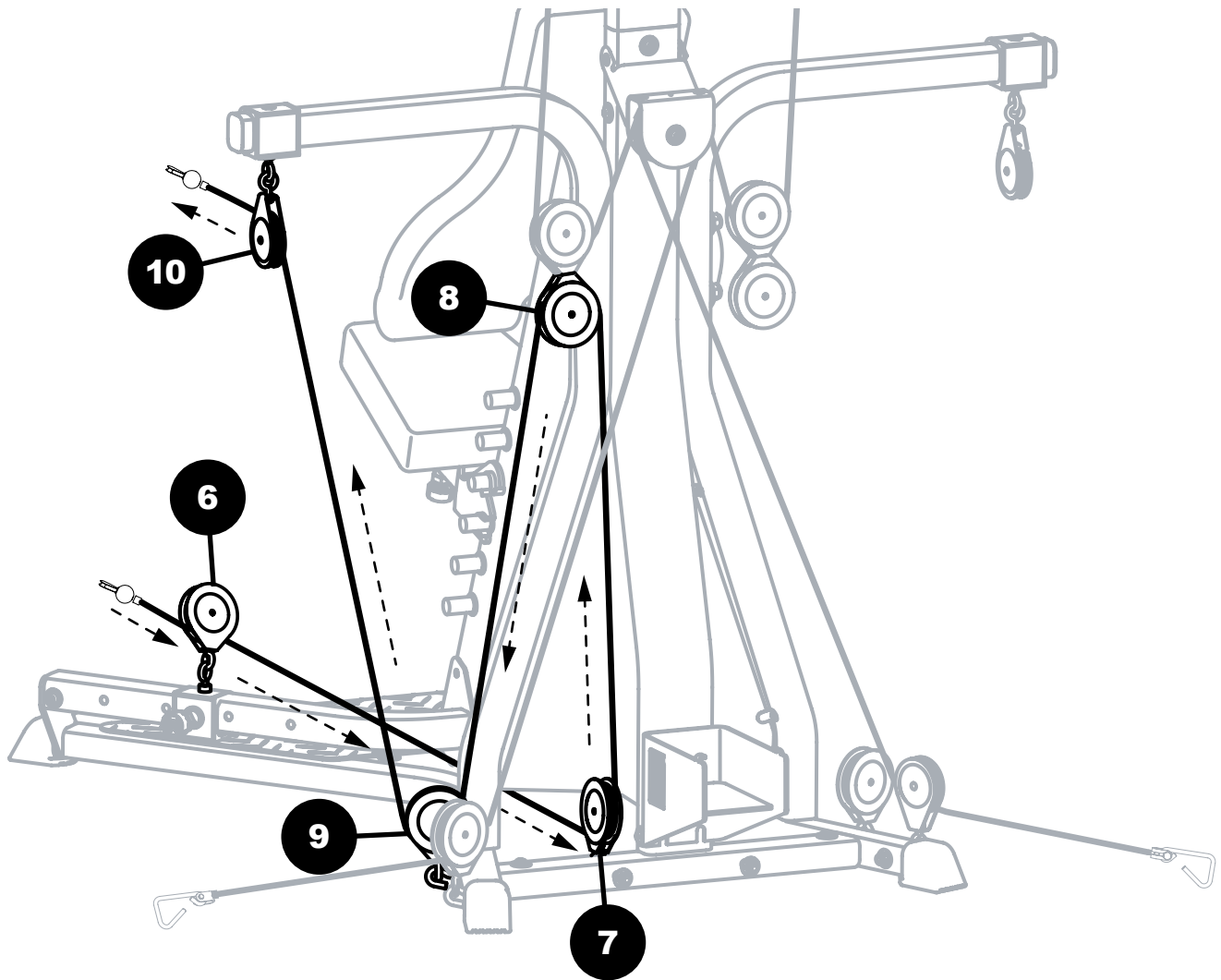

Figure 19d - Rod Hooks Storage on Lat Pulley Housing

Assembly Guide



Step 20 Cable and Pulley Routing – Connect Right Squat Cable through the Floating and Main Assembly Pulleys

Slide the Right Squat Frame Pulley (6) to the furthest back hole, as indicated in **Figure 20**.

Unwrap the Right Squat Cable from the (6) Pulley and guide the Cable, threading under and through the Rear Cross Bar Pulley (7), and up through the Floating (8) Pulley. Follow the arrows as indicated in **Figure 20**.

Continue to guide the Cable down through the Inner Right Frame Rail Pulley (9), up through the Right Pulley Arm Pulley (10), as shown in **Figure 20**.

Finally, insert the Cable End through the Cable End Stop Ball and attach the Cable Core, as completed during Step 19.

Assembly Guide

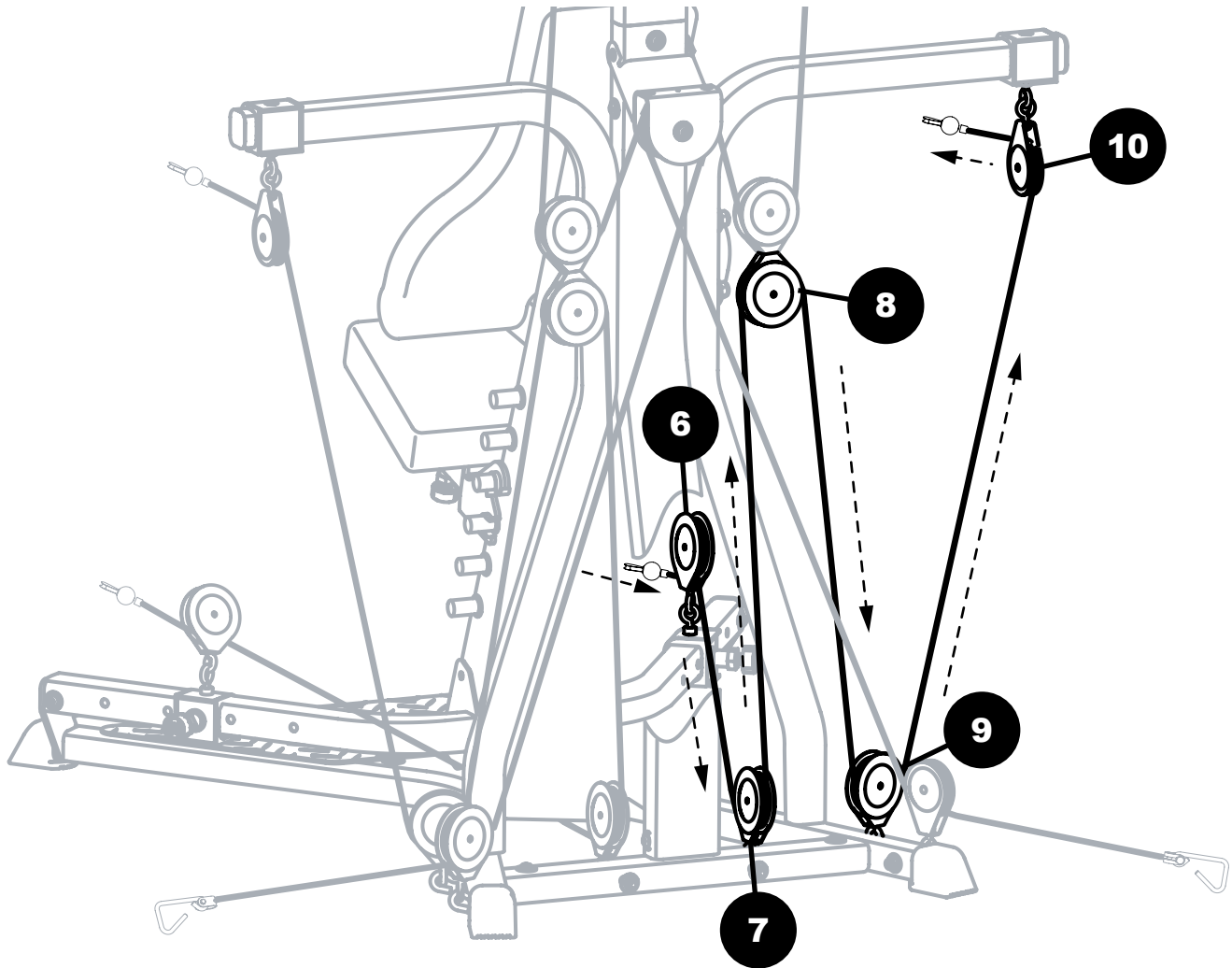

Step 20b Cable and Pulley Routing – Connect Left Squat Cable through the Floating and Main Assembly Pulleys

Repeat the same procedure completed during Step 20 for the Left Squat Cable.

Assembly Guide

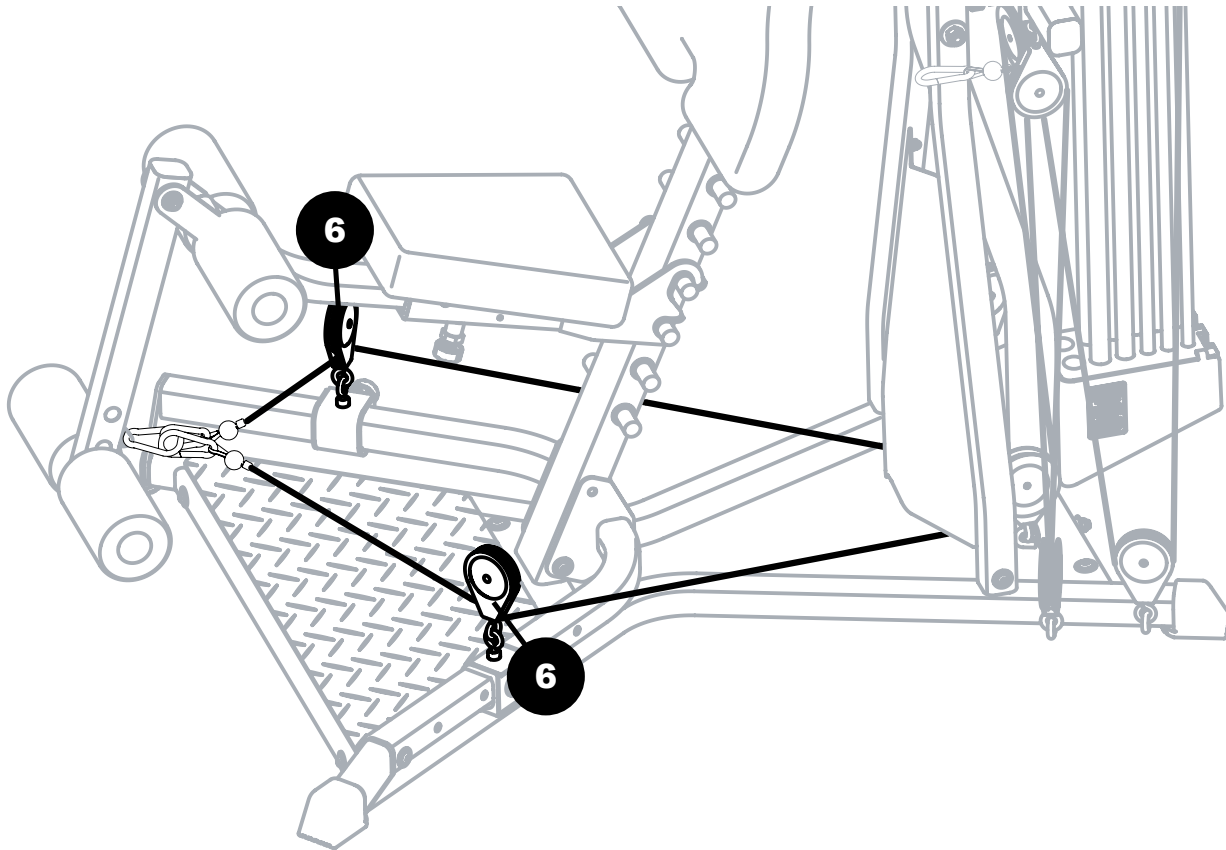

Step 21 Cable & Pulley Routing

Attach the hooks on the ends of the Left and Right Squat Cables to the Hook installed onto the Leg Extension, as shown in **Figure 21**..

Step 22 Final Inspection

Please inspect your machine to ensure that all fasteners are tight and components are properly assembled. Review all warnings affixed to machine.

Congratulations! You have successfully completed assembly of your Bowflex Xtreme® 2 SE home gym!



WARNING

Failure to visually check and test assembly before use can cause damage to the Bowflex Xtreme® 2 SE home gym and serious injury to users and bystanders and can also compromise the effectiveness of your exercise program.

Important Contact Numbers

If you need assistance, please have both the serial number of your machine and the date of purchase available when you contact the appropriate Nautilus office listed below.

OFFICES IN THE UNITED STATES:

E-mail: customerservice@nautilus.com

- **TECHNICAL/CUSTOMER SERVICE**
Nautilus, Inc.
World Headquarters
16400 SE Nautilus Drive
Vancouver, Washington, USA 98683
Phone: 800-NAUTILUS (800-628-8458)
Email: customerservice@nautilus.com
Fax: 877-686-6466

- **CORPORATE HEADQUARTERS**
Nautilus, Inc.
World Headquarters
16400 SE Nautilus Drive
Vancouver, Washington, USA 98683
Phone: 800-NAUTILUS (800-628-8458)

INTERNATIONAL OFFICES:

For technical assistance and a list of distributors in your area, please call or fax one of the following numbers.

- **INTERNATIONAL CUSTOMER SERVICE**
Nautilus International S.A.
Rue Jean Prouvé 6
1762 Givisiez / Switzerland
Tel: + 41-26-460-77-77
Fax: + 41-26-460-77-70
Email: technics@nautilus.com

- **BUSINESS OFFICES:**
 - **SWITZERLAND OFFICE**
Nautilus Switzerland S.A.
Tel: + 41-26-460-77-66
Fax: + 41-26-460-77-60

 - **GERMANY and AUSTRIA OFFICE**
Nautilus GmbH
Tel: +49-2204-610-27
Fax: +49-2204-628-90

 - **ITALY OFFICE**
Nautilus Italy s.r.l.
Tel: +39-051-664-6201
Fax: +39-051-664-7461

 - **UNITED KINGDOM OFFICE**
Nautilus UK Ltd.
Tel: +44-1908-267-345
Fax: +44-1908-267-346

 - **CHINA OFFICE**
Nautilus Representative Office
Tel: +86-21-523-707-00
Fax: +86-21-523-707-09

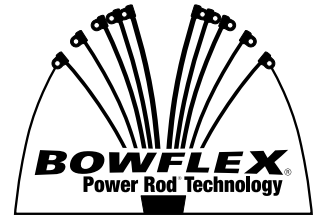

BOWFLEX
XTREME 2 SE

© 2007 Nautilus, Inc. All Rights Reserved.

Nautilus, Inc. World Headquarters, 16400 S.E. Nautilus Drive, Vancouver, Washington USA 98683 1-800-NAUTILUS (1-800-628-8458)
Bowflex, Bowflex Xtreme, Power Rod and the Bowflex logo are either registered trademarks or trademarks of Nautilus, Inc. All other trademarks are trademarks of their respective companies.

Printed in China