

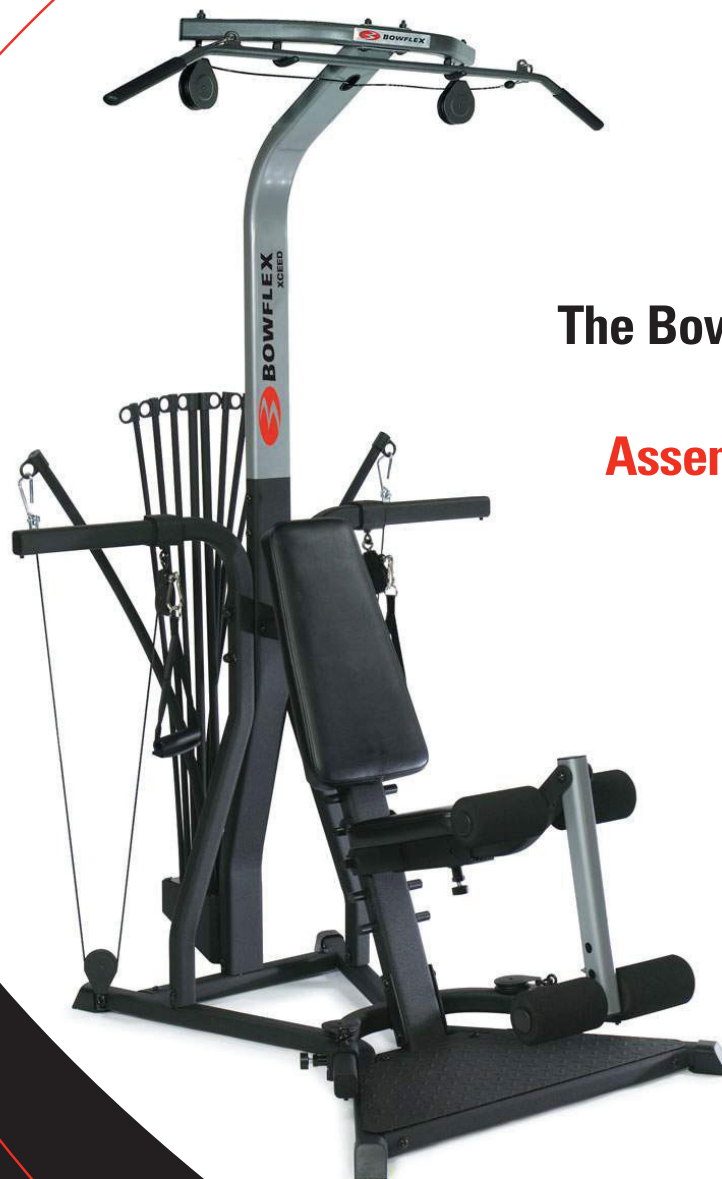

# **BOWFLEX**

## **XCEED**



### **The Bowflex Xceed™ Home Gym Assembly Manual**

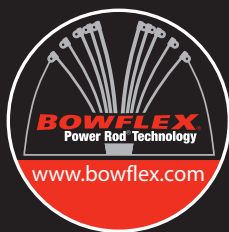



**Congratulations** on your commitment to fitness and your purchase of the Bowflex Xceed™ home gym. Before assembling your Bowflex Xceed™ home gym please read the Assembly Manual and follow the Important Safety Precautions. For information on how to use your Bowflex Xceed™ home gym refer to the Bowflex Xceed™ Owner's Manual.

Nautilus, Inc.  
16400 S.E. Nautilus Drive  
Vancouver, Washington, USA 98683

1-800-NAUTILUS (1-800-628-8458)  
Fax (800) 898-9410  
Nautilus.com  
Bowflex.com

## ***Table of Contents***

<b>Specifications / Approvals</b> .....	1
<b>Important Safety Precautions</b> .....	2
<b>Getting To Know Your Machine</b> .....	3
<b>Parts Reference Guide</b> .....	4
<b>Hardware Guide</b> .....	6
<b>Assembly Guide</b> .....	7-15





# Specifications / Approvals

## Product Specifications:

<b>Product Weight</b>	157 lbs. (71 kg)
<b>Product Dimensions</b>	53" (135 cm) long x 49" (124 cm) wide x 82" (208 cm) high
<b>Workout Area</b>	96" (244 cm) long x 78" (198 cm) wide
<b>Number of Exercises</b>	Over 60
<b>Power Rod® Resistance</b>	210 lbs. (95 kg)
<b>Power Rod® Upgradability</b>	310 lbs. (141 kg.) 410 lbs. (186 kg.)
<b>User Weight Limit</b>	300 lbs. (136 kg)

## Regulatory Approvals:



Meets:  
 EN957-1 Class H  
 EN957-2 Class H



Meets:  
 ASTM F2276-05  
 ASTM F2216-05





## ***Important Safety Precautions***

---

### **IMPORTANT SAFETY INSTRUCTIONS**

The following definition applies to the word “**Warning**” found throughout this manual:



Used to call attention to **POTENTIAL** hazards that could result in personal injury or loss of life.

---



**READ ALL INSTRUCTIONS BEFORE ASSEMBLING THE MACHINE.**





# Getting to Know Your Machine

---

## Before You Assemble

Please take the time to read all assembly instructions before attempting to assemble your Bowflex Xceed™ home gym. Select where you are going to locate your machine carefully. The best place for your Bowflex Xceed™ home gym is on a hard, level surface.

Select a workout area that provides a minimum clearance behind the rod box of 0.5 ft (15 cm) and a total width of 6.5 ft (2.0 m). Allow a minimum of 3.0 ft (0.9 m) free space in front of the machine.

## Basic Assembly Principles

Here are a few basic tips that will make your assembly of the Bowflex Xceed™ home gym quick and easy. By using these principles, you can simplify each process and save yourself extra time and effort.

1. To make the assembly process go faster, gather the pieces you need for each step and thoroughly read the assembly instructions for that step prior to starting assembly for the step.
2. When tightening a locknut on a bolt, use a combination wrench to grip the locknut and ensure that it is fastened securely.
3. When attaching two pieces, gently lift and look through the bolt holes to help guide the bolt through the holes.
4. As a general rule, and for all bolts and nuts on your Bowflex Xceed™ home gym, turn bolts or nuts toward the right to tighten and left to loosen. Or you can remember the mnemonic: “Righty tighty, lefty loosey.”

**IMPORTANT: LEAVE ALL CABLES COILED AND WRAPPED UNTIL YOUR BOWFLEX XCEED™ HOME GYM IS FULLY ASSEMBLED.**





# Parts Reference Guide

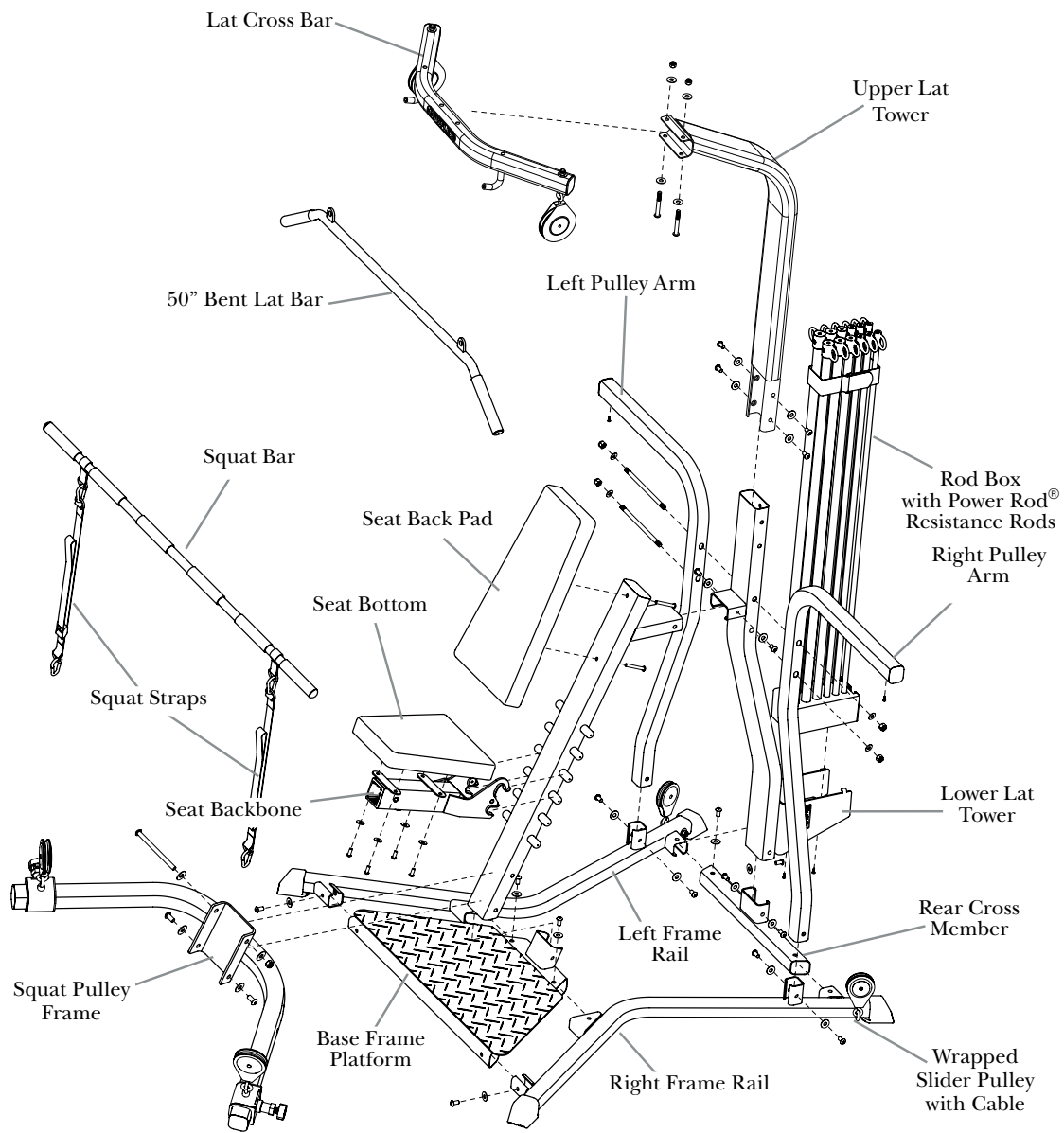



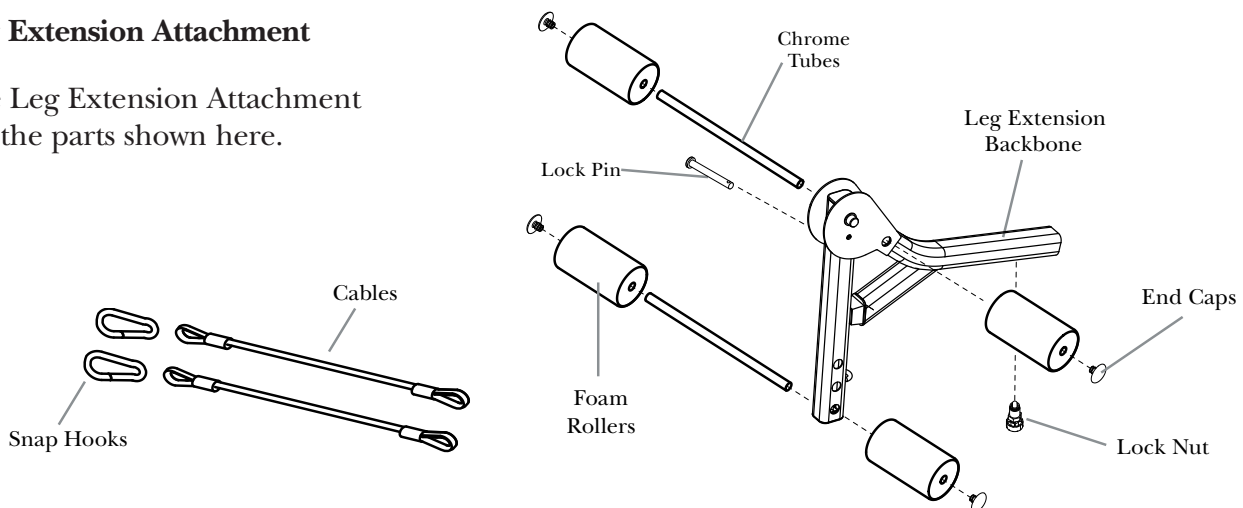

## Leg Extension Attachment

The Leg Extension Attachment has the parts shown here.

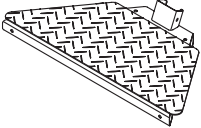
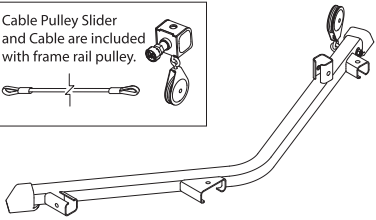
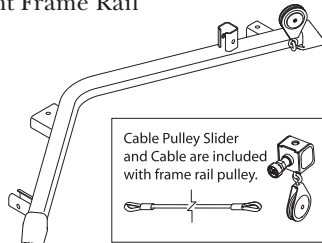
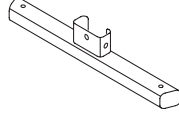
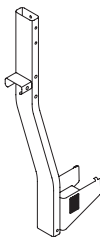
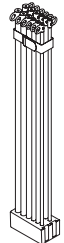
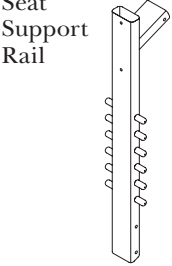
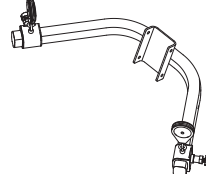
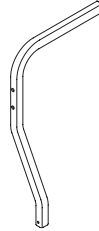

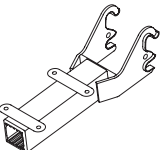

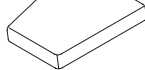
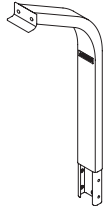
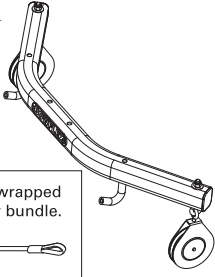
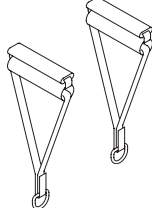
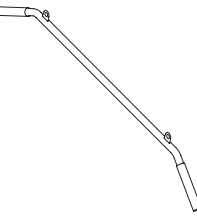
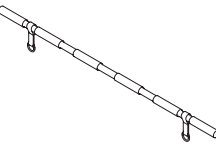
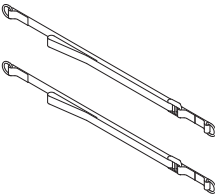
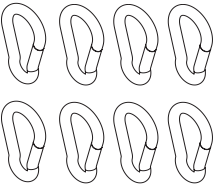
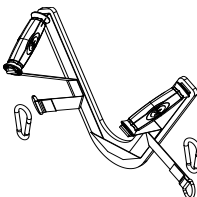
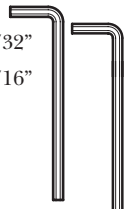
# Parts Reference Guide

<b>Base Frame</b> 	<b>Left Frame Rail</b>  <p>Cable Pulley Slider and Cable are included with frame rail pulley.</p>	<b>Right Frame Rail</b>  <p>Cable Pulley Slider and Cable are included with frame rail pulley.</p>	<b>Rear Cross Member</b> 		
<b>Lower Lat Tower Frame</b> 	<b>Rod Box w/ Rods</b> 	<b>Seat Support Rail</b> 	<b>Squat Pulley Frame</b> 	<b>Left Pulley Arm</b> 	<b>Right Pulley Arm</b> 
<b>Seat Backbone</b> 	<b>Seat Back</b>  <b>Seat Bottom</b> 	<b>Upper Lat Tower</b> 	<b>Lat Cross Bar with Pulleys</b>  <p>One cable is wrapped in each pulley bundle.</p>	<b>2 Hand Grips</b> 	
<b>50" Bent Lat Bar</b> 	<b>Squat Bar</b> 	<b>2 Squat Straps</b> 	<b>8 Snap Hooks</b> 	<b>Abdominal Crunch Shoulder Harness</b> 	<b>Tools Included:</b> 2 Hex Wrenches 7/32" 3/16" 

NOTE: Specifications Subject to Change Without Notice

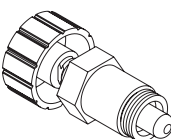
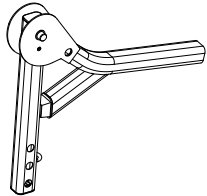
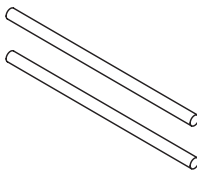
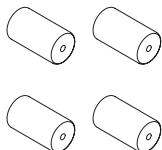
## Leg Extension Parts

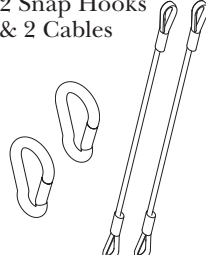
<b>Lock Knob</b> 	<b>Leg Extension Backbone</b> 	<b>2 Chrome Tubes (3/4")</b> 	<b>4 Foam Rollers</b> 	<b>4 End Caps (3/4")</b> 	<b>2 Snap Hooks &amp; 2 Cables</b> 
---------------------------------------------------------------------------------------------------------	----------------------------------------------------------------------------------------------------------------------	------------------------------------------------------------------------------------------------------------------------------------	---------------------------------------------------------------------------------------------------------------	----------------------------------------------------------------------------------------------------------------------------------	-----------------------------------------------------------------------------------------------------------------------------

NOTE: Specifications Subject to Change Without Notice



# Hardware Guide

## Tools you will need:

You will need the tools listed below to complete the assembly of your Bowflex Xceed™ home gym. If you don't have these tools, you can find them at any hardware or department store.

- 7/16" Combination Wrench
- 9/16" Combination Wrench
- Adjustable Wrench
- Socket Wrench Set
- Phillips Screw Driver
- Flat Blade Screw Driver
- Rubber Mallet
- Utility Knife
- Scissors
- Allen wrenches (included)

(NOTE: Drawings not to scale.)

### Button Head Screws:

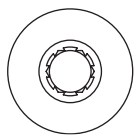

Qty: 4  
(5/16" x 3/4")

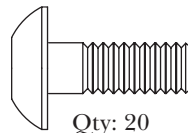

Qty: 20  
(3/8" x 3/4")

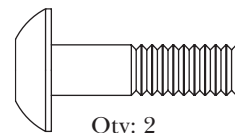

Qty: 2  
(3/8" x 1") (in separate bag with washers)

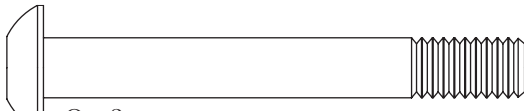

Qty: 2  
(5/16" x 2 1/2")

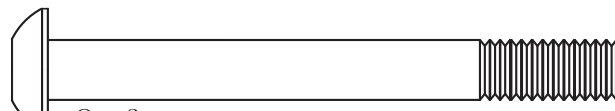

Qty: 2  
(3/8" x 3")

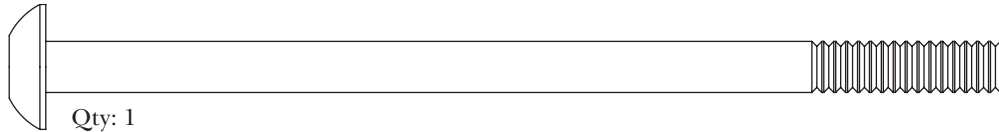

Qty: 1  
(3/8" x 5")

### Flat Washers:

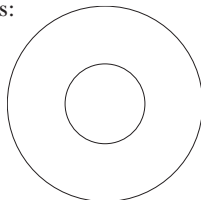

Qty: 4  
(1/2")

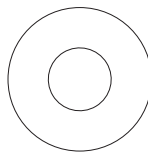

Qty: 26  
(3/8")

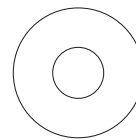

Qty: 6  
(5/16")

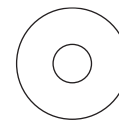

Qty: 3  
(1/4")

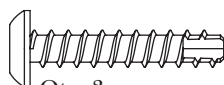

Qty: 3  
Self Threading Screws (#10 x 1")

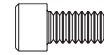

Qty: 2  
Cap Screws (1/4" x 1/2")

### Nylock Nuts:

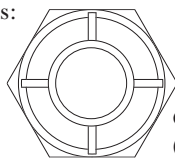

Qty: 4  
(1/2")

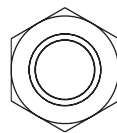

Qty: 3  
(3/8")

Qty: 2 Threaded Studs  
(1/2" x 9 1/2")

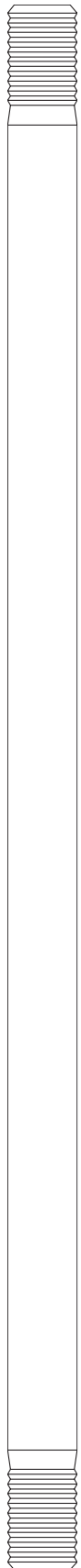



# Assembly Guide

## Step 1 Base Frame Assembly

### Parts:

- Base Frame
- Left Frame Rail
- Right Frame Rail
- Rear Cross Member

### Hardware:

- 6 Button Head Screws ( 3/8" X 3/4")
- 6 Flat Washers (3/8")

**Tool:** 7/32" Allen Wrench  
(or Hex Wrench)

**1-1** Lay all parts on floor as shown.

**1-2** Insert Frame Rail connectors into the Base Frame and Rear Cross Member. Secure with screws and washers as shown.

**Finger tighten screws at this time.**

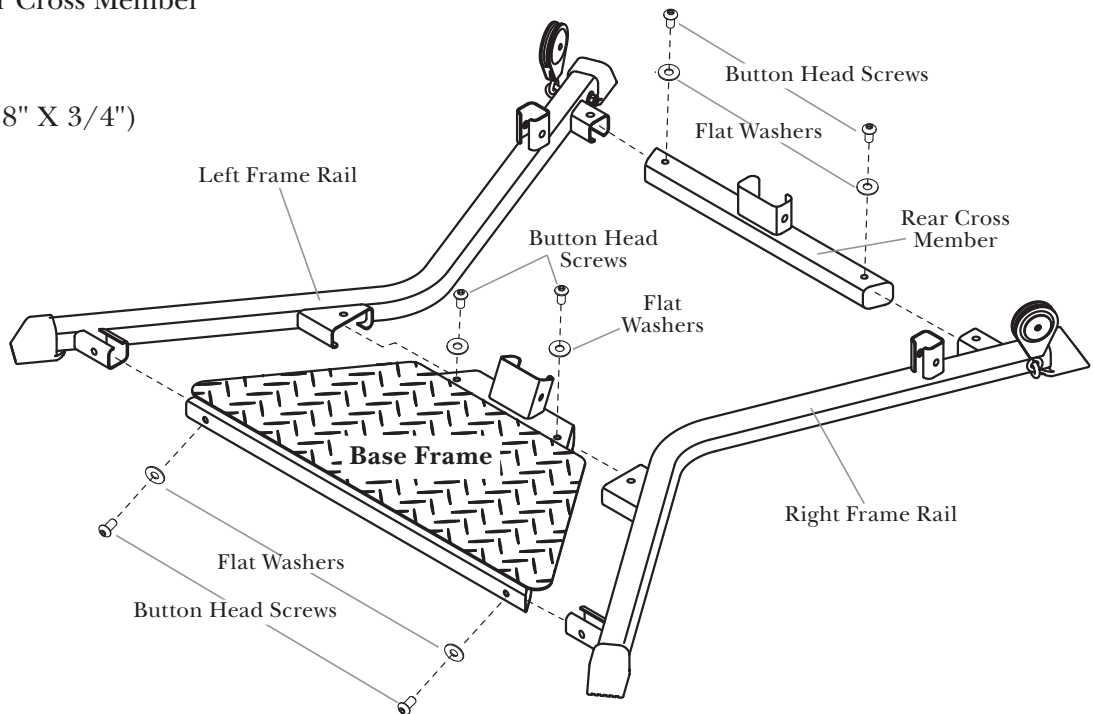

## Step 2 Lower Lat Tower Assembly

### Parts:

- Lower Lat Tower Frame
- Rod Box with Power Rod® Pack

### Hardware:

- 3 Self Threading Screws (#10 X 1")
- 3 Flat Washers (1/4")

**Tool: Phillips Screw Driver**

**2-1** Lay parts on floor as shown. Firmly slide Rod Box into Lower Lat Tower Frame.

**2-2** Fasten the Rod Box to the Lower Lat Tower Frame with screws and washers as shown. Tighten screws until snug.

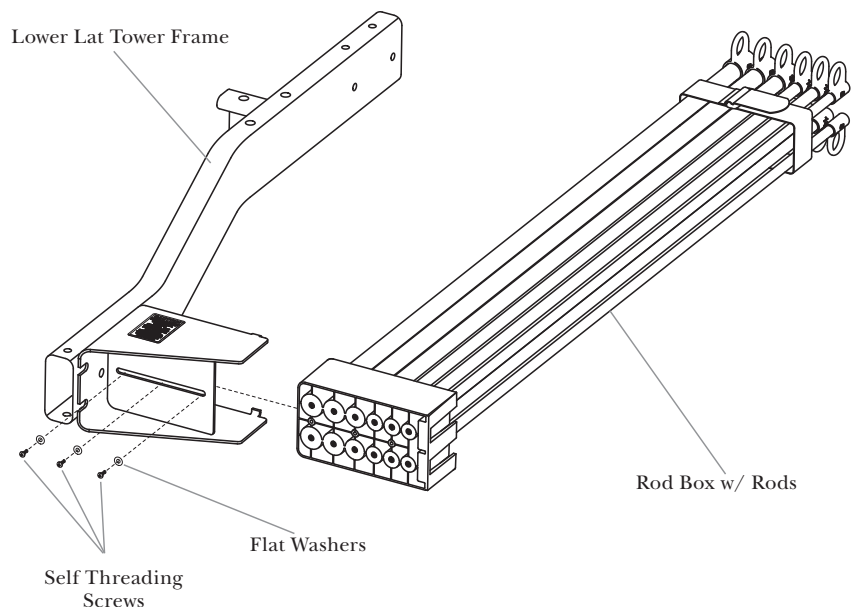



# Assembly Guide

## Step 3 Install Lower Lat Tower Assembly

### Parts:

- Lower Lat Tower Assembly
- Base Frame Assembly

### Hardware:

- 2 Button Head Screws (3/8" X 3/4")
- 2 Flat Washers (3/8")

**Tool:** 7/32" Hex Wrench

**3-1** Align the Lower Lat Tower Assembly over the Base Frame. Push the bottom of the Lower Lat Tower onto the connector of the Rear Cross Member as shown.

**3-2** Secure Lower Lat Tower Assembly using screws and washers as shown.

**Finger tighten screws at this time.**

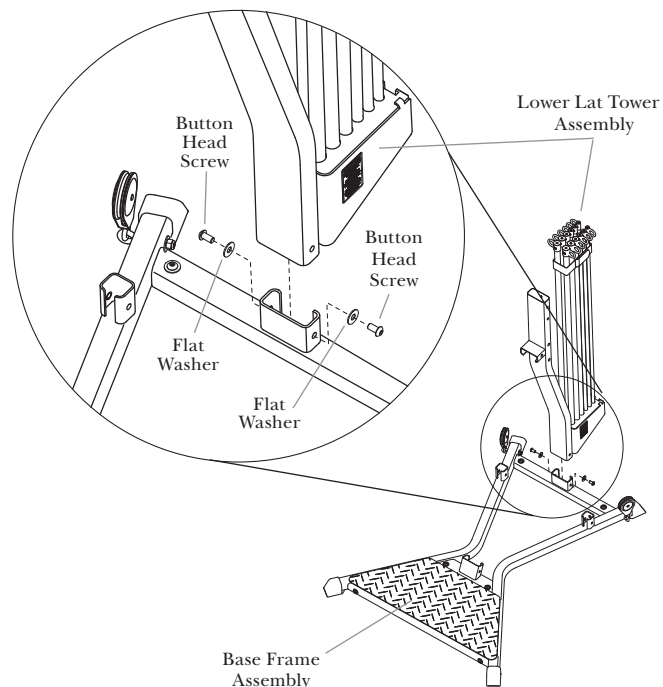

## Step 4 Install Seat Support Rail

### Parts:

- Seat Support Rail
- Base Frame Assembly

### Hardware:

- 2 Button Head Screws (3/8" X 3/4")
- 2 Flat Washers (3/8")

**Tool:** 7/32" Hex Wrench

**4-1** Slide the bottom of the Seat Support Rail onto the Base Frame connector as shown.

**4-2** Slide the top of the Seat Support Rail onto the Lower Lat Tower Assembly connector as shown. Secure using screws and washers as shown.

**Finger tighten screws at this time.**

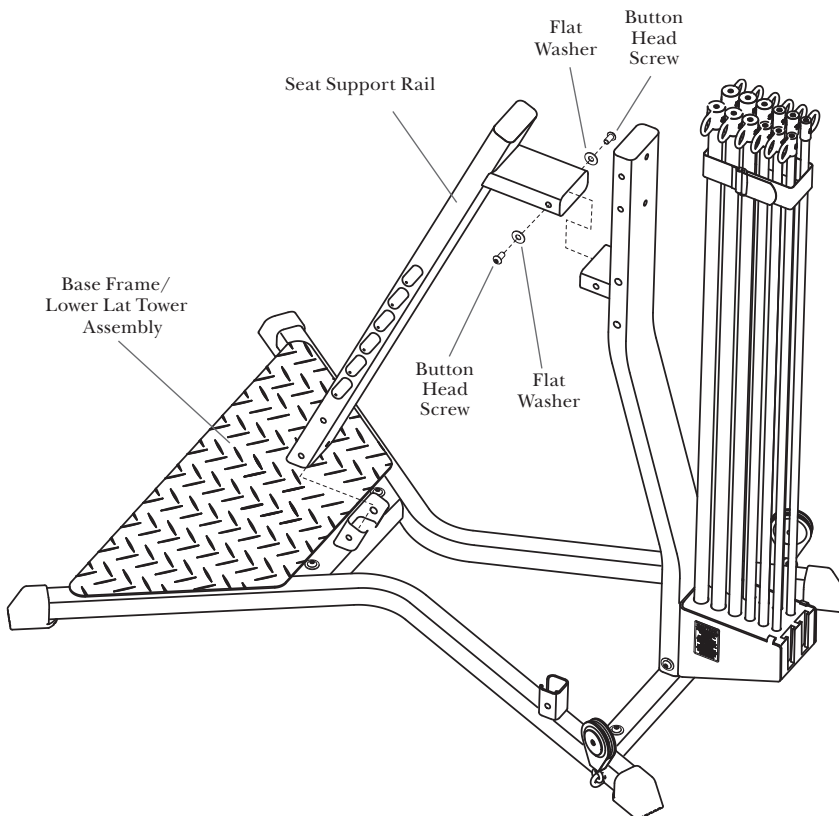



# Assembly Guide

## Step 5 Install Squat Pulley Frame

### Parts:

- Squat Pulley Frame Assembly
- Main Assembly

### Hardware:

- 1 Button Head Screw (3/8" X 5")
- 1 Nylock Nut (3/8")
- 2 Button Head Screws (3/8" X 1")
- 4 Washers (3/8")

**Tools:** 7/32" Hex Wrench & Adjustable or Socket Wrench

- 5-1** Place the Squat Pulley Frame behind the Seat Support Rail and align the top screw holes. Secure using a 3/8" X 5" screw, washer and nut in the top hole as shown.
- 5-2** Install screws and washers into the bottom holes of the Squat Pulley Frame as shown.

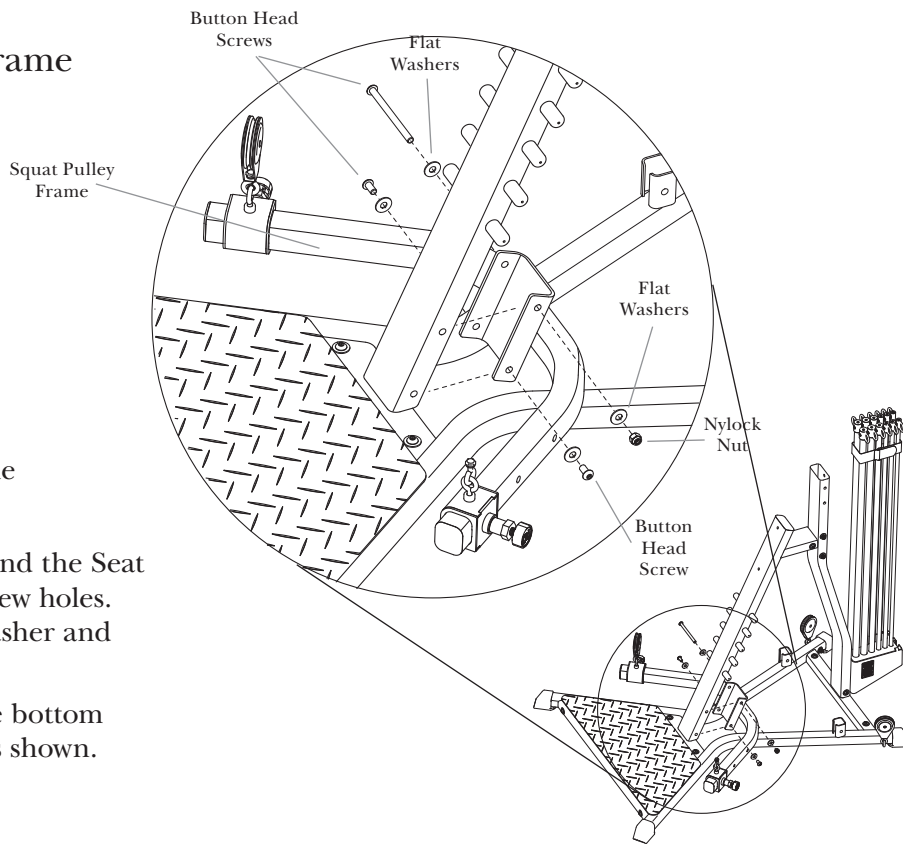

## Step 6 Install Pulley Arms

### Parts:

- Right Pulley Arm
- Left Pulley Arm
- Main Assembly

### Hardware:

- 4 Washers (3/8")
- 4 Button Head Screws (3/8" X 3/4")

**Tools:** 7/32" Hex Wrench

- 6-1** Slide Left and Right Pulley Arms onto the connectors on the base frame as shown.
- 6-2** Secure Pulley Arms to Base Frame using screws and washers as shown.

**Finger tighten screws at this time.**

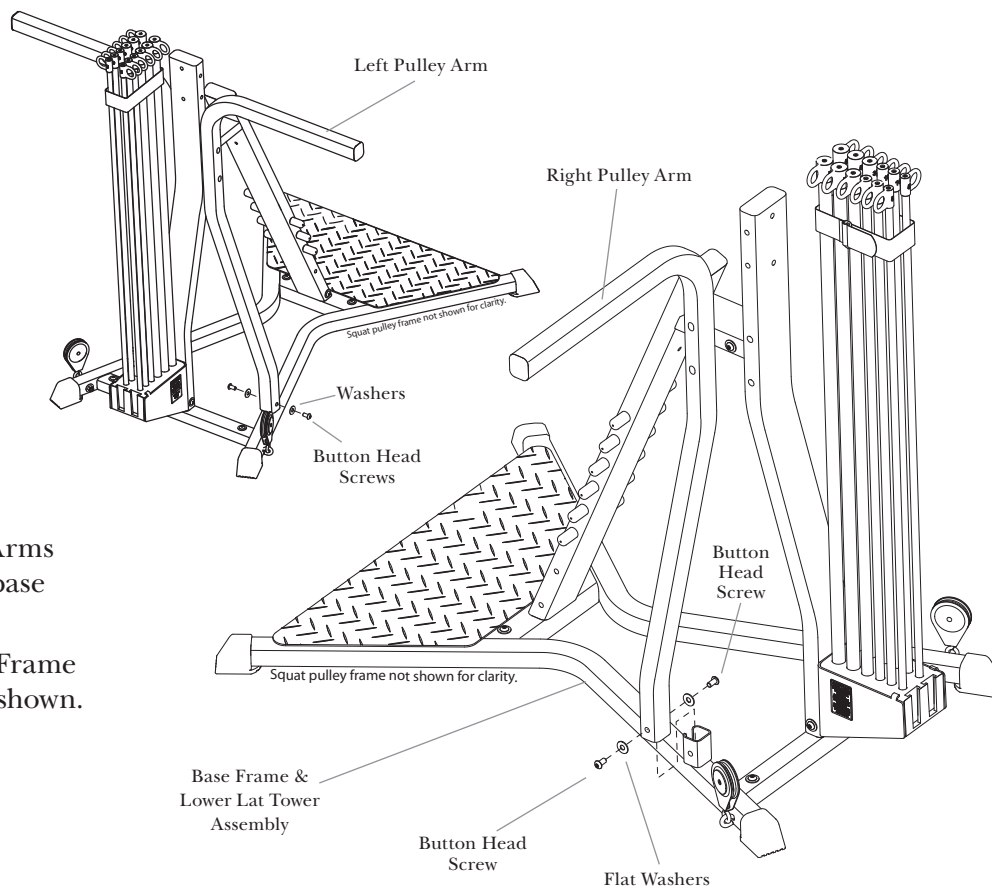



# Assembly Guide

## Step 7 Secure Pulley Arms

### Hardware:

- 2 Threaded Studs (1/2" X 9 1/2")
- 4 Nylock Nuts (1/2")
- 4 Washers (1/2")

**Tool:** Rubber Mallet

**7-1** Align the two holes in the Pulley Arms with those in the Lower Lat Tower Assembly and secure using threaded studs, washers and nuts as shown.

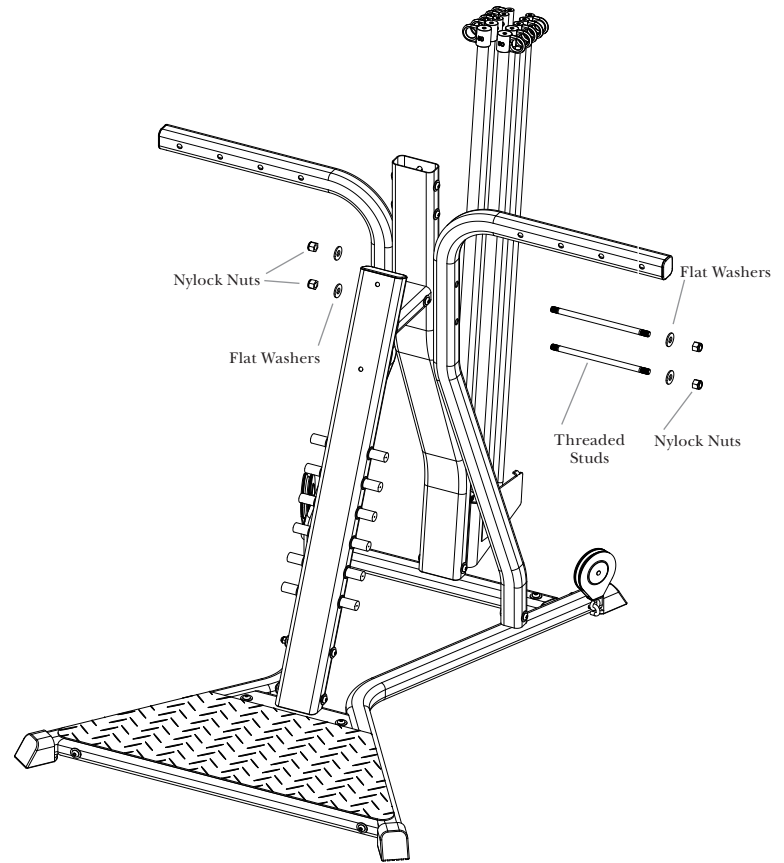

## Step 8 Install Slider Pulleys

### Parts:

- 2 Slider Pulleys with Cable Assembly
- Main Assembly

### Hardware:

- 2 Cap Screws (1/4" X 1/2")

**Tools:** 3/16 Hex Wrench

**8-1** Unwrap the Slider Pulley and uncoil the cable.

**8-2** Install a Slider Pulley onto each Pulley Arm as shown. Choose any of the four holes to secure.

**8-3** Install a cap screw into the underside of each Pulley Arm, as shown.

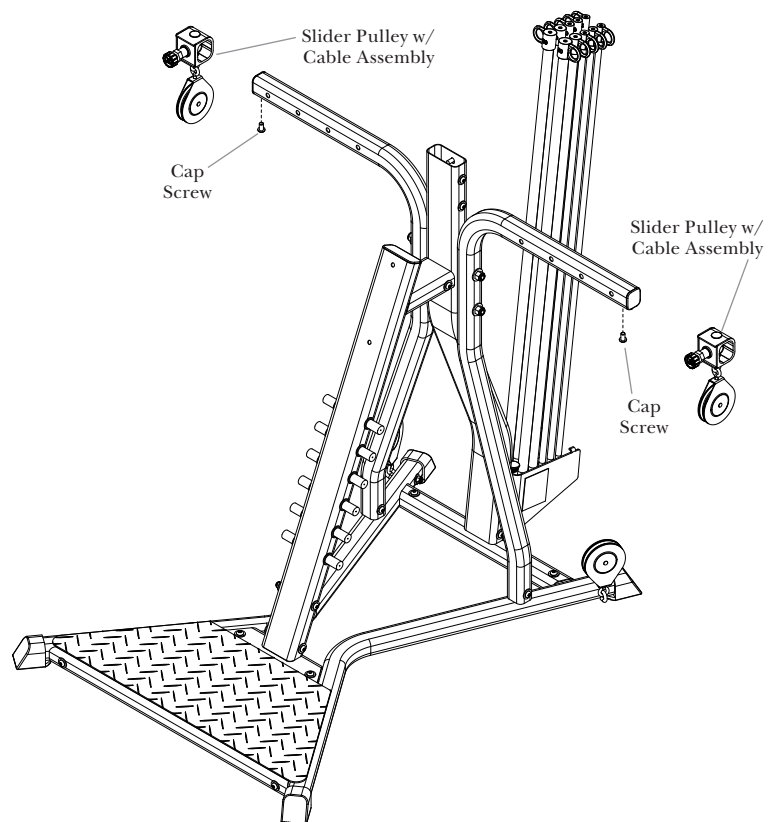



# Assembly Guide

## Step 9 Seat Assembly

### Parts:

- Seat Backbone
- Seat Bottom

### Hardware:

- 4 Button Head Screws (5/16" X 3/4")
- 4 Washers (5/16")

**Tool:** 3/16" Hex Wrench

**9-1** Install the Seat Backbone to the underside of the Seat Pad using screws and washers as shown.

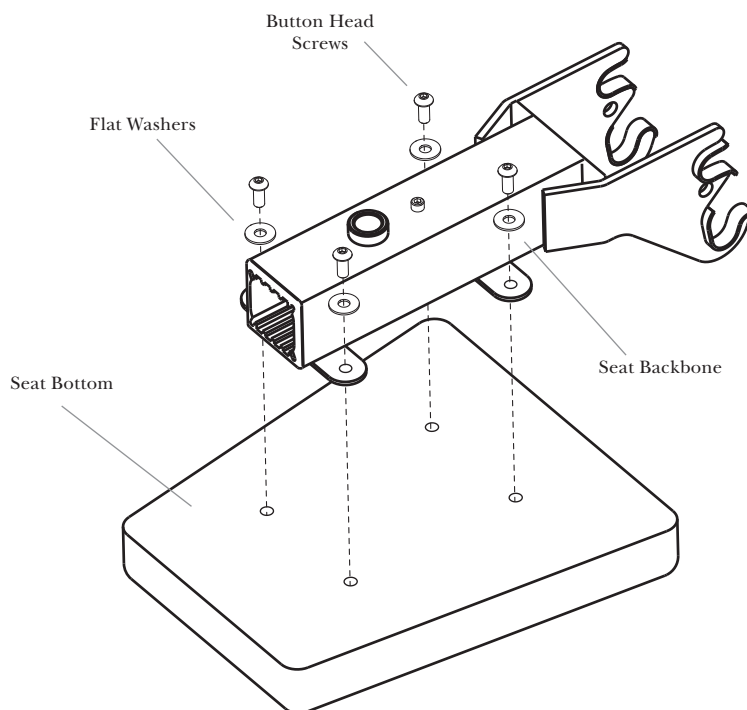

## Step 10 Leg Extension Assembly

### Parts:

- Leg Extension Backbone
- 2 Chrome Tubes
- 4 Foam Rollers
- 4 End Caps

**Tool:** Rubber Mallet

**10-1** Insert Chrome Tubes through the upper hole and one of the lower holes in the Leg Extension. (Select hole for your comfort level.)

**10-2** Slide Foam Rollers onto the Chrome Tubes and secure with end caps. A rubber mallet may be needed to secure the end caps.

**NOTE:** The Leg Extension may be adjusted during workout to best suit your height and personal preferences.

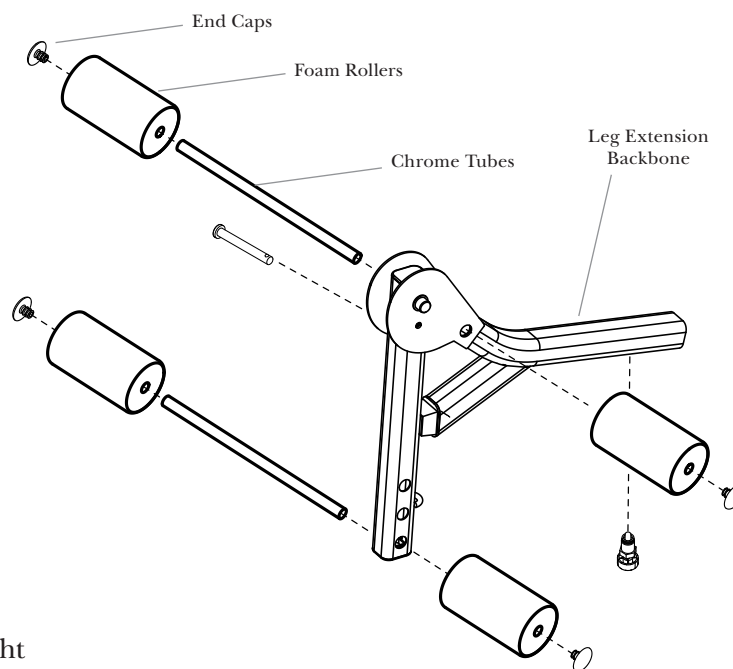



## Assembly Guide

### Step 11 Install Optional Leg Extension Assembly

#### Parts:

- Leg Extension Assembly
- Lock Knob

**11-1** Insert Leg Extension Backbone into open end of Seat Backbone as shown.

**11-2** Align one hole of the Leg Extension with the hole in the Seat Backbone to fit your height and secure with the Lock Knob as shown.

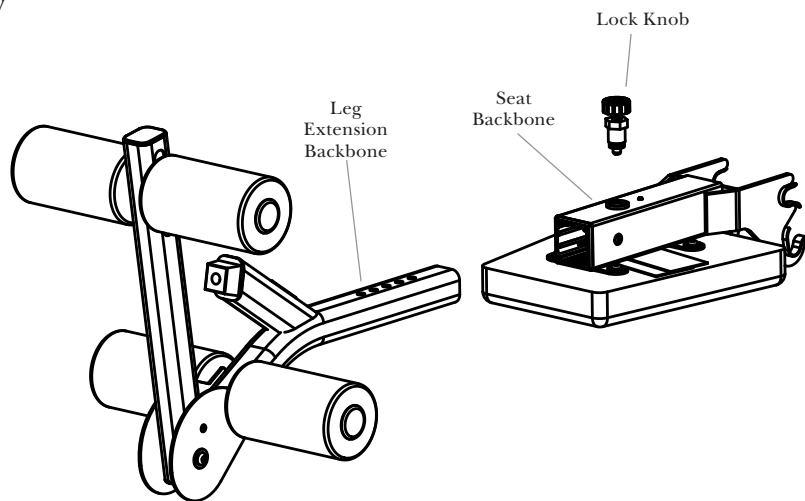

### Step 12 Install Seat Assembly

#### Parts:

- Seat Assembly
- Main Assembly

**12-1** Align the top two hooks on the Seat Backbone with one of the lower pairs of pins on the Seat Support Rail.

**12-2** Tip seat front up and slide hooks onto pins. Rotate seat down and back to use.

**Note:** Use lower pins until the seat back is installed. Reverse procedure to remove seat.

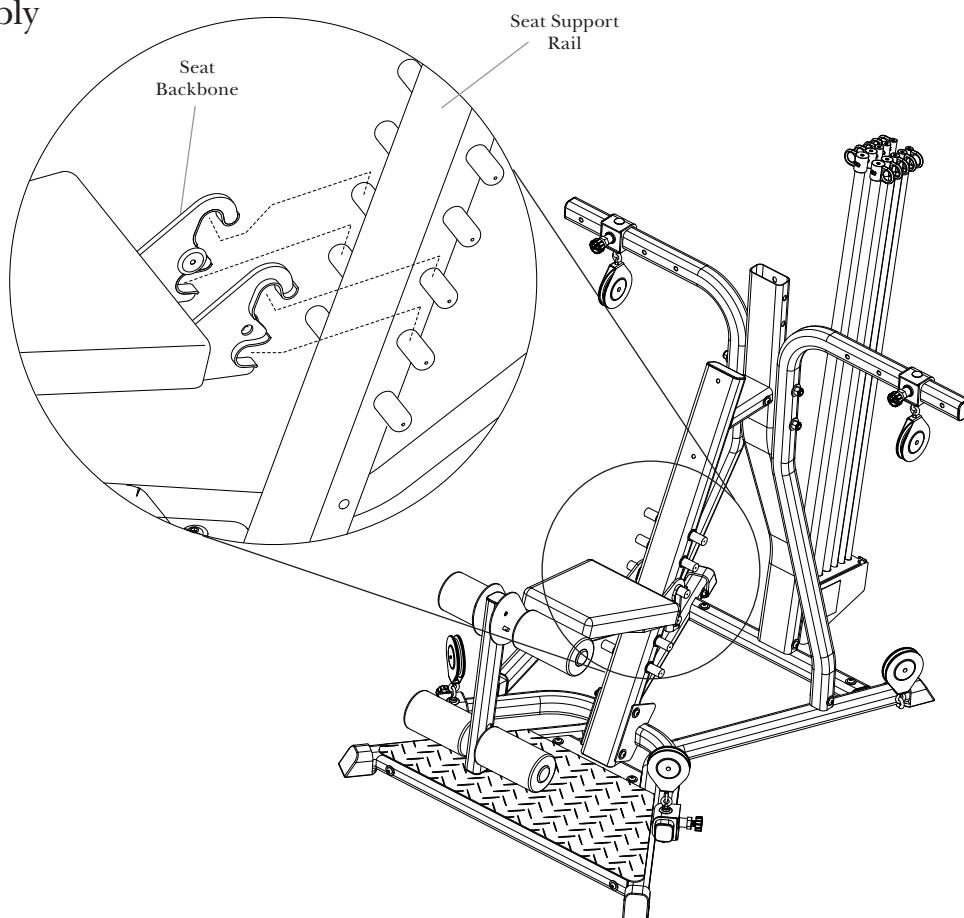



# Assembly Guide

## Step 13 Install Seat Back Pad

**Note:** The back of the Seat Back Pad has two pairs of holes. Select the appropriate set based on your height.

### Parts:

- Seat Back Pad
- Main Assembly

### Hardware:

- 2 Button Head Screws (5/16" X 2 1/2")
- 2 Washers (5/16")

**Tool:** 3/16" Hex Wrench

**13-1** Position Seat Back Pad against the Seat Support Rail and align the screw holes for your height with those on the Seat Support Rail.

**13-2** Secure Seat Back Pad to the Seat Support Rail using screws and washers as shown.

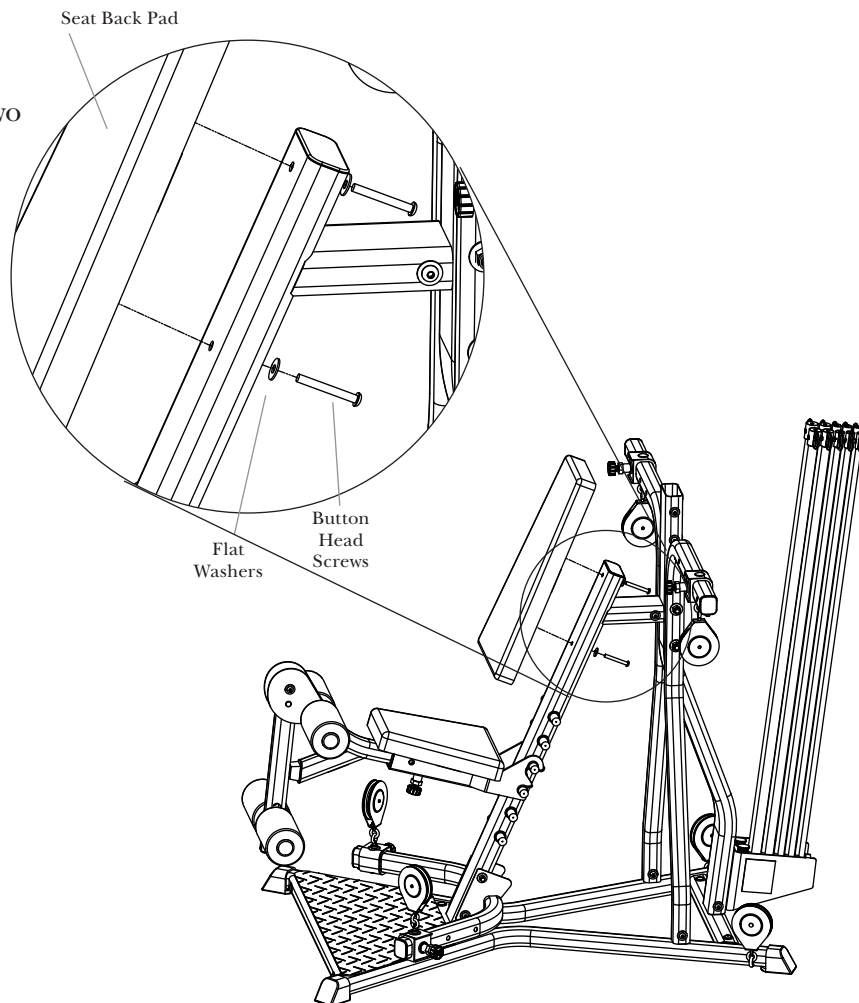

## Step 14 Upper Lat Tower Assembly

### Parts:

- Upper Lat Tower
- Lat Cross Bar

### Hardware:

- 2 Button Head Screws (3/8" X 3")
- 2 Washers (3/8")
- 2 Nylock Nuts (3/8")

**Tool:** 7/32" Hex Wrench and Adjustable Wrench

**14-1** Align the two holes on the Lat Cross Bar with those on the Upper Lat Tower as shown.

**14-2** Secure using washers and screws as shown.

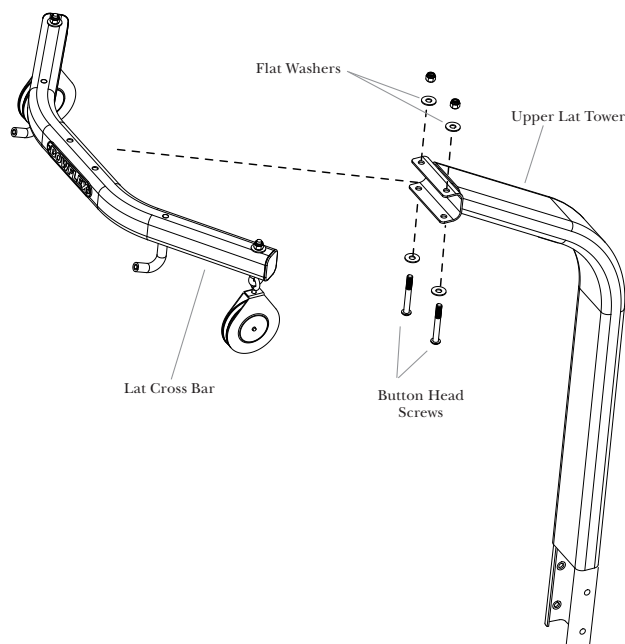



# Assembly Guide

## Step 15 Install Upper Lat Tower Assembly

### Parts:

- Upper Lat Tower Assembly
- Main Assembly

### Hardware (1:1):

- 6 Button Head Screws (3/8" X 3/4")
- 6 Washers (3/8")

### Tool: 7/32" Hex Wrench

**15-1** Position the Upper Lat Tower Assembly over the Lower Lat Tower Assembly.

**15-2** Slide the Upper Lat Tower onto the Lower Lat Tower and secure with screws and washers as shown.

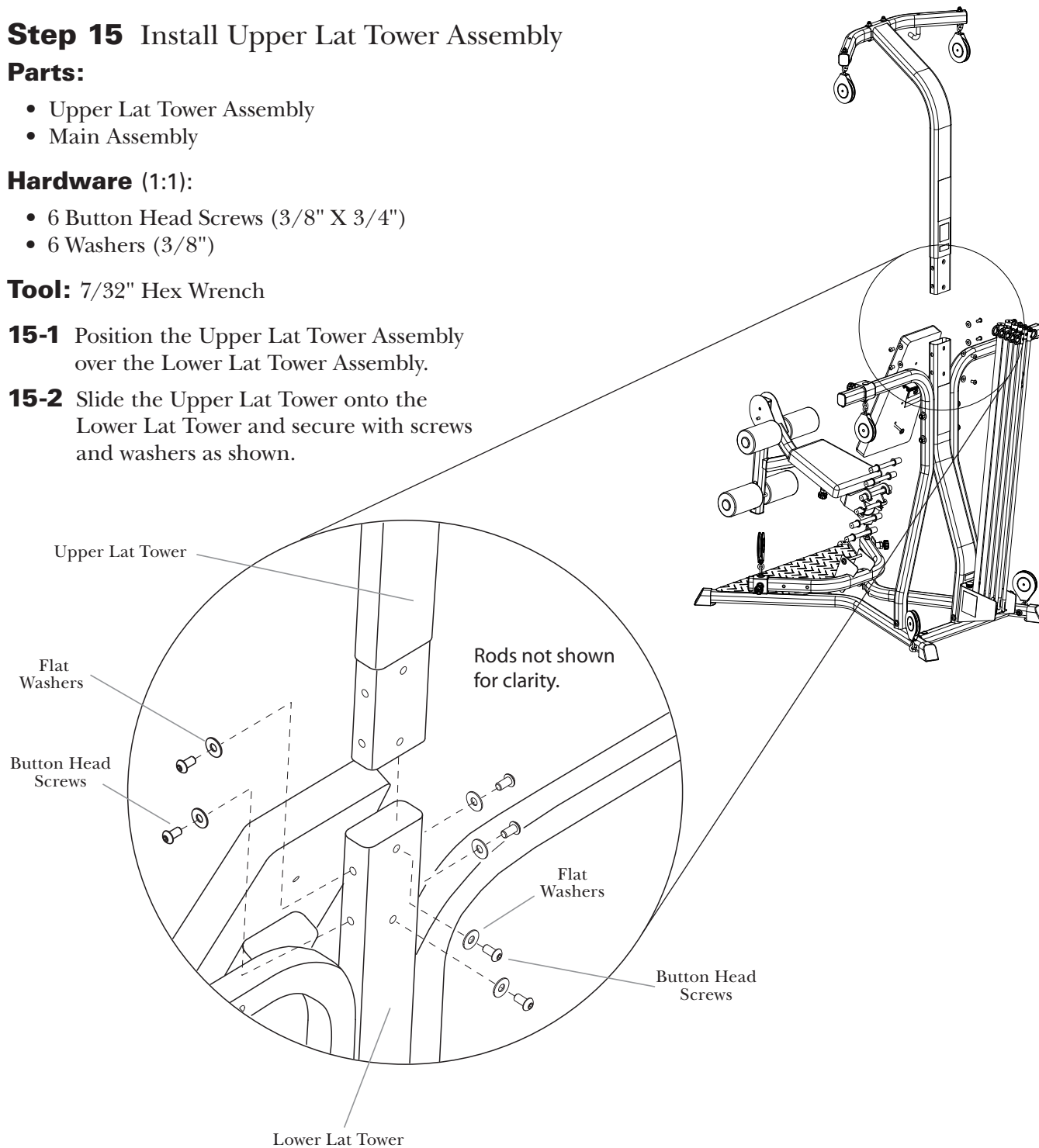

## Step 16 Tighten Hardware

**16-1** Carefully go over the entire Bowflex Xceed™ home gym and tighten all hardware before proceeding to the next step. Pay close attention to the hardware installed in Steps 1, 3, 4, and 6.







# Assembly Guide

## Step 17 Connect Cables

**Parts:** Completed Bowflex Xceed™ home gym

**Tool:** Scissors or other cutting tool

**17-1** Remove the wrapping from around the coiled cable and pulley attached to the Right and Left Frame Rails.

**17-2** Remove the wrapping from around the coiled cable and pulley attached to the left and right side of the lat tower.

**17-3** Attach the cable to the home gym following the routing for the various exercise positions.

**NOTE:** As you use your home gym, you will connect the cables and pulleys in a variety of ways to perform the exercises. Refer to the Owner's Manual for information on using the Bowflex Xceed™ home gym..

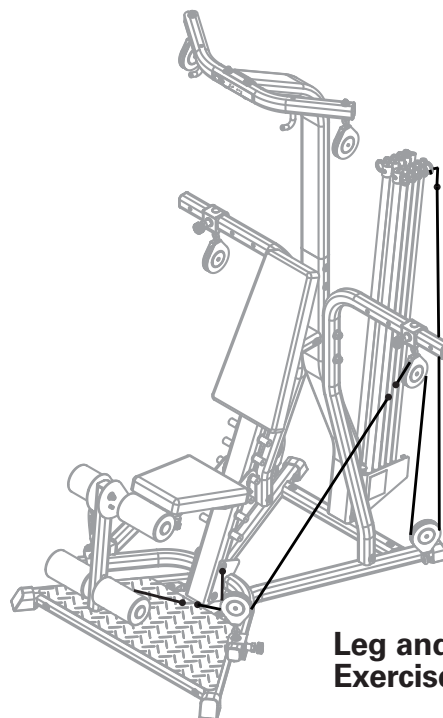

**Leg and Squat Exercises**

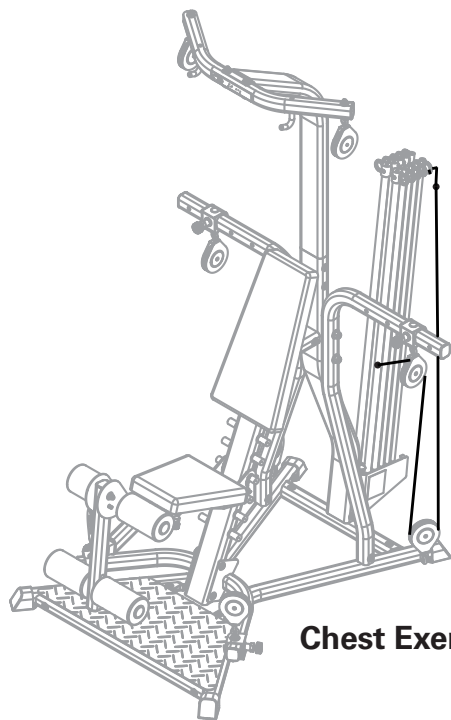

**Chest Exercises**

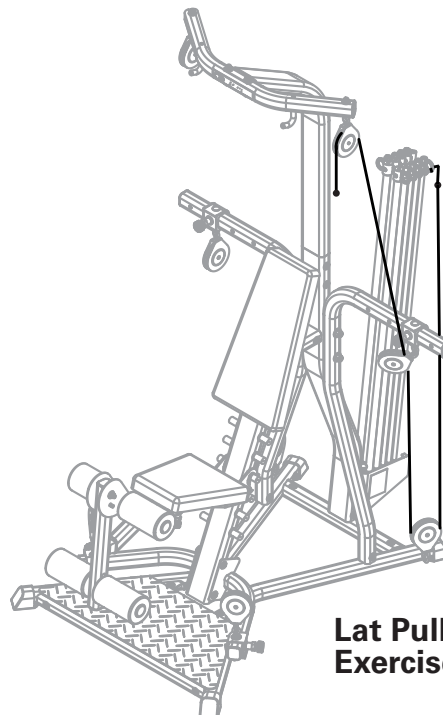

**Lat Pulldown Exercises**

## Step 18 CONGRATULATIONS!

You have successfully completed assembly of your Bowflex Xceed™ home gym! Please inspect your machine to ensure that all fasteners are tight and components are properly assembled. Review all warnings affixed to machine.

 **WARNING**

**Failure to visually check and test assembly before use can cause damage to the Bowflex Xceed™ home gym and serious injury to users and bystanders and can also compromise the effectiveness of your exercise program.**





# Important Contact Numbers

If you need assistance, please have both the serial number of your machine and the date of purchase available when you contact the appropriate Nautilus office listed below.

## OFFICES IN THE UNITED STATES:

E-mail: [customerservice@nautilus.com](mailto:customerservice@nautilus.com)

- **NAUTILUS INNOVATION CENTER**  
Nautilus, Inc.  
1886 Prairie Way  
Louisville, Colorado, USA 80027  
Vancouver, Washington, USA 98683  
Phone: 800-NAUTILUS (800-628-8458)  
Email: [customerservice@nautilus.com](mailto:customerservice@nautilus.com)  
Fax: 800-898-9410
  
- **TECHNICAL/CUSTOMER SERVICE**  
Nautilus, Inc.  
World Headquarters  
16400 SE Nautilus Drive  
Vancouver, Washington, USA 98683  
Phone: 800-NAUTILUS (800-628-8458)  
Email: [customerservice@nautilus.com](mailto:customerservice@nautilus.com)  
Fax: 877-686-6466
  
- **CORPORATE HEADQUARTERS**  
Nautilus, Inc.  
World Headquarters  
16400 SE Nautilus Drive  
Vancouver, Washington, USA 98683  
Phone: 800-NAUTILUS (800-628-8458)

## INTERNATIONAL OFFICES:

For technical assistance and a list of distributors in your area, please call or fax one of the following numbers.

- **INTERNATIONAL CUSTOMER SERVICE**  
Nautilus International S.A.  
Rue Jean Prouvé 6  
1762 Givisiez / Switzerland  
Tel: + 41-26-460-77-77  
Fax: + 41-26-460-77-70  
Email: [technics@nautilus.com](mailto:technics@nautilus.com)

## BUSINESS OFFICES:

- **SWITZERLAND OFFICE**  
Nautilus Switzerland S.A.  
Tel: + 41-26-460-77-66  
Fax: + 41-26-460-77-60
  
- **GERMANY and AUSTRIA OFFICE**  
Nautilus GmbH  
Tel: +49-2204-610-27  
Fax: +49-2204-628-90
  
- **ITALY OFFICE**  
Nautilus Italy s.r.l.  
Tel: +39-031-51-10-86  
Fax: +39-031-34-24-97
  
- **UNITED KINGDOM OFFICE**  
Nautilus UK Ltd.  
Tel: +44-1908-267-345  
Fax: +44-1908-267-346
  
- **CHINA OFFICE**  
Nautilus Representative Office  
Tel: +86-21-523-707-00  
Fax: +86-21-523-707-09





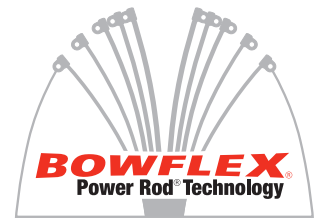

© 2006 Nautilus, Inc. All Rights Reserved.

Nautilus, Inc. World Headquarters, 16400 S.E. Nautilus Drive, Vancouver, Washington USA 98683 1-800-NAUTILUS (1-800-628-8458)  
Bowflex, Bowflex Xceed, Power Rod and the Bowflex logo are either registered trademarks or trademarks of Nautilus, Inc. All other  
trademarks are trademarks of their respective companies.

Printed in China

